

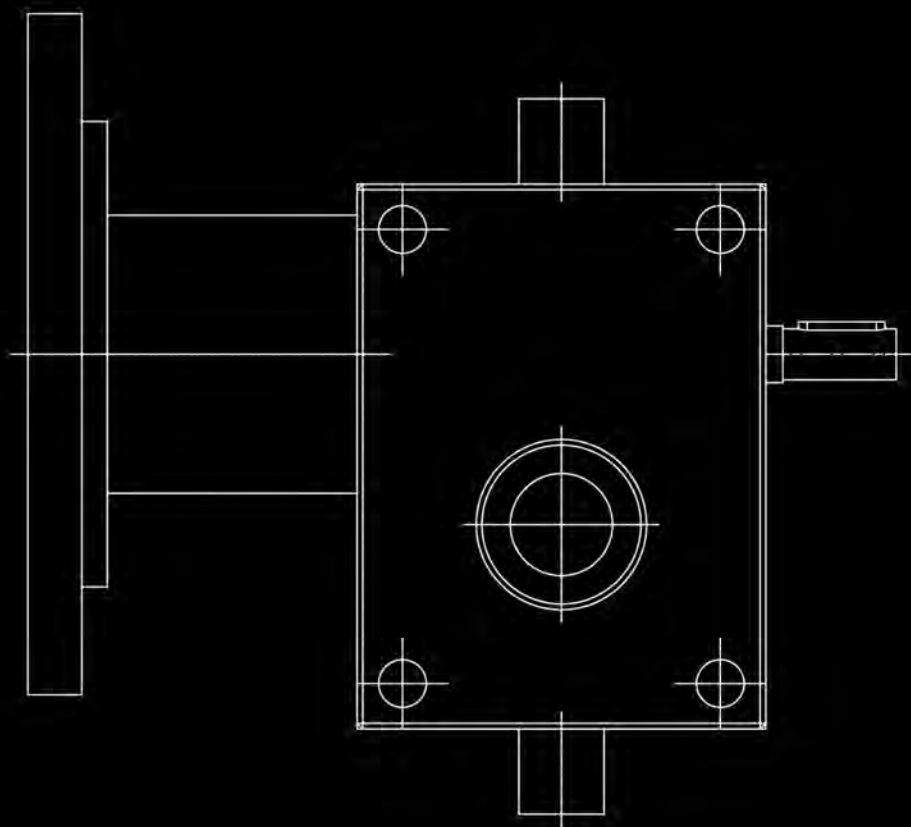

# MECHANICAL WORM SCREWJACKS

MADE IN ITALY

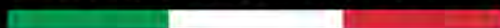



# WORM SCREW JACKS



The new line of Worm Screw Jacks named CHT (Chiaravalli High Tech) integrates and completes our range of Mechanical Transmission products.

This new line of products is manufactured using high quality materials, manufactured with absolute precision, making use of the modern machinery fleet of the companies belonging to Chiaravalli Group SpA.

The basic elements that make up the final product "Screw Jack" are made in large series, rigorously checked and put in stock. Special virtual software developed by Chiaravalli Group SpA enables our customers to first view the various elements of the required screw jack and then, in the second phase, to order it with absolute precision and confidence.

Chiaravalli Group SpA is engaged to ensure the delivery of this product in very short time, with quality and precision.



# NEW SERIES

# HEAVY LINE

CHS 9 · CHS 10 · CHS 12 · CHS 14 · CHS 16

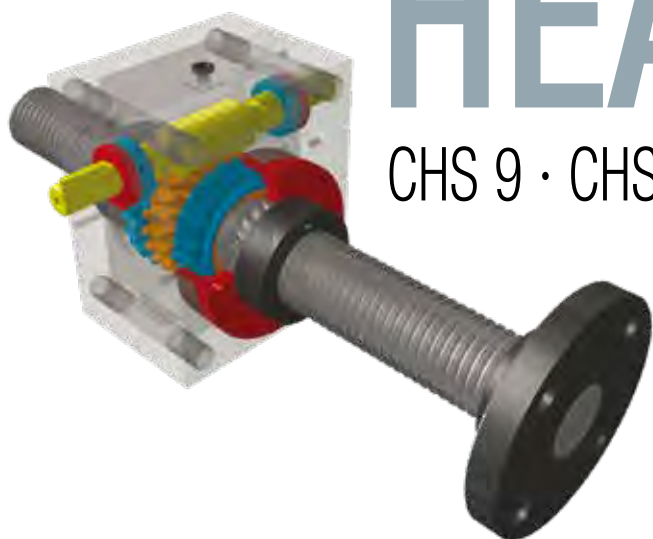

With our experience, we have designed and realized the **New Worm Screw Jack Series Heavy Line**.

Only two points to remark the mechanical and dynamic performances of this new range:

- 1 • monolithic structure, totally obtained by mechanical machining operations
- 2 • mechanical assembly realised with axial ball bearings



Technical data from pages 52 to pages 71



# INDEX

Introduction	Page	10
Screw jack designation	Page	11
General features	Page	12
Dynamic loads	Page	12
Static loads	Page	13
Radial load	Page	14
Manual handling / Drive by electric motor	Page	15
Lubrication	Page	17
Compression load	Page	18

## CHS 1

Screw jack model TS	Page	20
Screw jack model RS		21
Screw jack performance		22

## CHS 2

Screw jack model TS	Page	24
Screw jack model RS		25
Screw jack performance		26

## CHS 3

Screw jack model TS	Page	28
Screw jack model RS		29
Screw jack performance		30

## CHS 4

Screw jack model TS	Page	32
Screw jack model RS		33
Screw jack performance		34

## CHS 5

Screw jack model TS	Page	36
Screw jack model RS		37
Screw jack performance		38

## CHS 6

Screw jack model TS	Page	40
Screw jack model RS		41
Screw jack performance		42

## CHS 7

Screw jack model TS	Page	44
Screw jack model RS		45
Screw jack performance		46

## CHS 8

Screw jack model TS	Page	48
Screw jack model RS		49
Screw jack performance		50





# INDEX

**CHS  
9**  
HEAVY LINE

Screw jack model TS Screw  
jack model RS Screw jack  
performance

Page 52  
53  
54

**CHS  
10**  
HEAVY LINE

Screw jack model TS Screw  
jack model RS Screw jack  
performance

Page 56  
57  
58

**CHS  
12**  
HEAVY LINE

Screw jack model TS Screw  
jack model RS Screw jack  
performance

Page 60  
61  
62

**CHS  
14**  
HEAVY LINE

Screw jack model TS Screw  
jack model RS Screw jack  
performance

Page 64  
65  
66

**CHS  
16**  
HEAVY LINE

Screw jack model TS Screw  
jack model RS Screw jack  
performance

Page 68  
69  
70

Ball screw and Screw jack  
Flanged single nut

Page 72  
Page 73

CHS 2 VRS - CHS 3 VRS CHS  
3 VRS - CHS 4 VRS CHS 4  
VRS - CHS 5 VRS

Page 74  
75  
76

Special mechanical worm screw jacks

Page 77

Configurations

Page 78

Options

Page 79-82

Protection tube

Page 83

Spare parts

Page 84

Safety nut

Page 86

Pivoting rigid protection - PO

Page 87

Mounting examples

Page 88

General sales conditions

Page 97





## INTRODUCTION

The new series of mechanical screw jack CHIARAVALLI, named CHS, is a product, the innovation of it is due to modularity which allows to supply a customized product in reasonable times.

The coupling with electric motors (either on normal, motor brake or explosion-proof motors) is guaranteed thanks to the predisposition to IEC B5 and B14 flanges.

This type of worm gear screw jack is used in many fields where it is necessary to lift considerable weights, such as automated production lines for sheet metal machinery, packaging, printing, textiles, plastics, food, renewable energy and more.

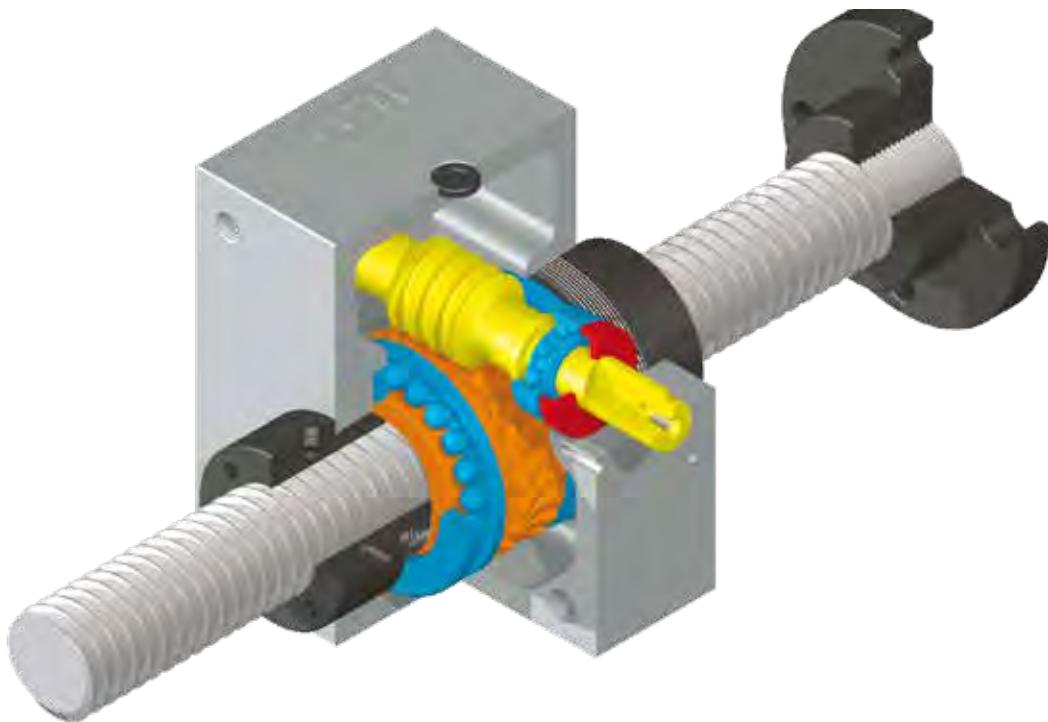

### PRODUCT FEATURES

- modularity
- customization
- high strength cast iron case
- hardened and ground worm gear
- long life lubrication inside, no threaded spindle

CHS Series screw jacks are manufactured in 13 sizes, customizable with all the accessories included in the catalogue, according to customers' requirements.



# SCREW JACK DESIGNATION

**CHS- -C -R - - - -PAM B --, Kw- P- -SP**

SIZE  
1-2-3-4-5-6-7-8-9-10-12-14-16

TRANSLATING SCREW **TS**  
ROTATING SCREW **RS**

STROKE mm

RATIO  
CHS 1 RATIO 5 - 20  
CHS 2 - 3 - 4 - 5 - 6 - 7 - 8 RATIO 5 - 10 - 30  
CHS 9 - 10 - 12 - 14 - 16 RATIO 10 - 30

SCREW ENDS TS - TF - TL - TP

INPUT SHAFT CONFIGURATION  
DX - Right SX - Left DE - Double input

INPUT MOTOR SHAFT  
M3 - Right - M4 - Left  
M1 - Right shaft DE  
M2 - Left shaft DE

OPTIONALS  
PR - PE - AR - AS - FC - PO - AM - CU - RG - CS - FCO - VRS - LO - CF - OX

MOTOR FLANGE SIZE  
56 - 63 - 71 - 80 - 90 - 100 - 112 - 132

MOTOR FLANGE TYPE (B5 O B14)

MOTOR POWER Kw (IF REQUIRED WITH MOUNTED MOTOR)

POLES MOTOR NUMBER: 4 - 6 (IF REQUIRED WITH MOUNTED MOTOR)

MOTOR TYPE: T-3PHASES, F-SELF BRAKING MOTOR (IF REQUIRED WITH MOUNTED MOTOR)

SP SPECIAL FEATURES - DESCRIPTION

SCREW JACK DESIGNATION



## GENERAL FEATURES

The worm gear based mechanical screw jack is one of the most economical and efficient mechanism for lifting and lowering loads, for push-pull applications. It can be used as a single unit or in multiple combinations, with manual or motorized drive. It is possible to link two or more screw jacks by shafts, couplings and right angle gear boxes, so that all the operations are perfectly synchronized. CHIARAVALLI worm screw jacks are built for nominal loads from 0,5 to 100 tons.

### ANALYSIS AND COMPOSITION OF LOAD

For the correct selection of the screw jack and, consequently, for its proper functioning, it is necessary to identify the actual load and the nature of the load, as better specified here below:

- STATIC loads
- DYNAMIC loads

These in turn can be:

- TRACTION loads
- COMPRESSION loads
- RADIAL loads (not allowed)
- COMPOUND loads

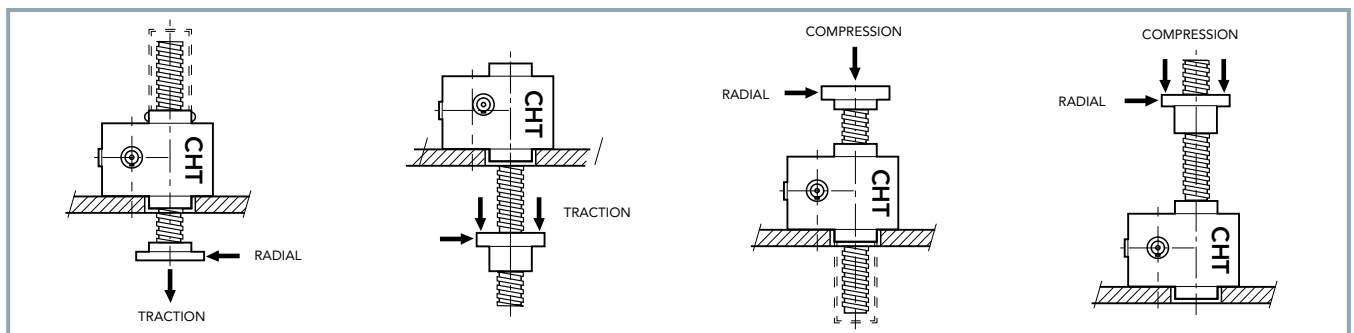

### DYNAMIC LOADS

#### TRACTION

The maximum traction load which can be applied to the screw jack, is determined by several factors: heat capacity, temperature, service, impact, radial loads not allowed

Make use of tables on pages 20 - 71 and page 18-19

#### COMPRESSION

The maximum load used in compression is influenced by several factors: length of the threaded shaft, thermal capacity, shock, temperature and type of service. Make use of tables on pages 20 - 71 In addition, the load causes a deflection of the same, thus requiring a further examination to be carried out using the table on page 18-19, according to the Euler's formula, linked to the type of external guides, so as to determine the maximum load.

#### RADIAL

In dynamic and static applications radial loads ARE NOT ALLOWED.

#### OVERTURNING MOMENT

As well as for radial loads, overturning moment are not allowed: overcome the problem by using appropriate sized external guides, that will avoid to subject the screw jack to such loads.



## STATIC LOADS

### TRACTION

The maximum load in tension applied to the Screw Jack is the max one foreseen by the tables of use on pages 20 - 71

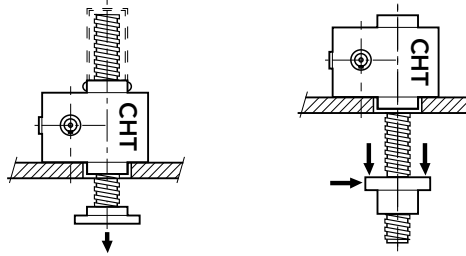

### COMPRESSION

The maximum load used in compression is influenced by the length of the threaded shaft, and can be checked in the chart on page 18-19, according to Euler's formula, linked in to the type of external guides.

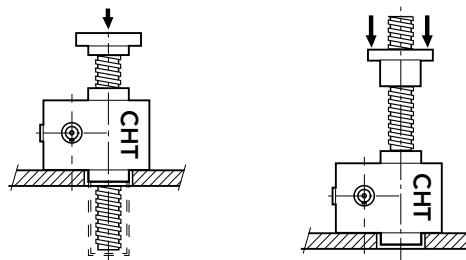

### RADIAL

These special loads cause a lateral shift of the shaft, provoking a dangerous deflection which would reduce the capacity of the screw jack. These therefore must be avoided.

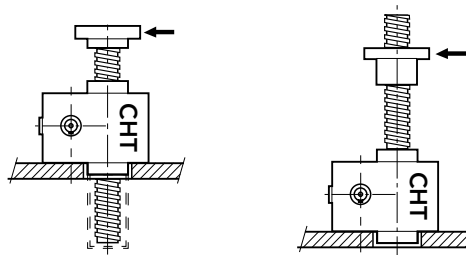

### OVERTURNINGS LOADS

As well as for radial loads, overturning moment are not allowed: overcome the problem by using appropriate sized external guides, that will avoid to subject the screw jack to such loads.

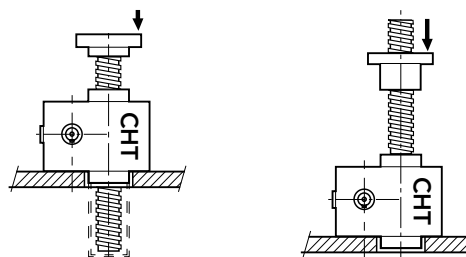



# GENERAL FEATURES

## WORM SCREW LOAD (INPUT SHAFT)

### MAXIMUM RADIAL LOAD ( $F_r$ )

The maximum load on the input shaft of the jack (worm screw) must not exceed the values specified in the table below, measured at half shaft.

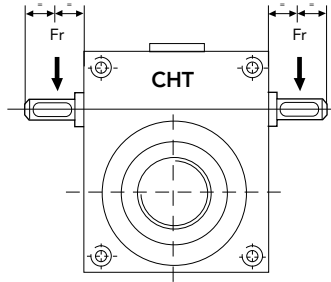

SIZE	CHS 1	CHS 2	CHS 3	CHS 4	CHS 5	CHS 6	CHS 7	CHS 8	CHS 9	CHS 10	CHS 12	CHS 14	CHS 16
$F_r$ (daN)	10	22	45	60	60	60	90	90	100	250	250	300	300

### TORQUE (daNm) (INPUT SHAFT)

For applications with multiple screw jack mounted in series, it is necessary not to exceed the values specified in the table below:

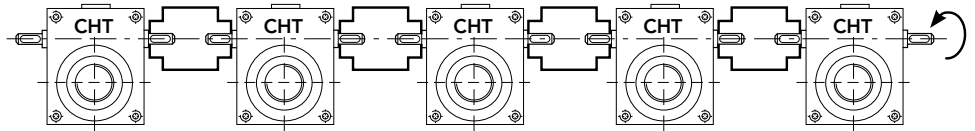

SIZE	CHS 1 MT (daNm)	CHS 2 MT (daNm)	CHS 3 MT (daNm)	CHS 4 MT (daNm)	CHS 5 MT (daNm)	CHS 6 MT (daNm)	CHS 7 MT (daNm)	CHS 8 MT (daNm)	CHS 9 MT (daNm)	CHS 10 MT (daNm)	CHS12 MT (daNm)	CHS 14 MT (daNm)	CHS 16 MT (daNm)
Fast speed (1/5)	2,30	5,40	7,00	49,00	49,00	49,00	80,5	80,5	-	-	-	-	-
Normal speed (1/10-1/20)	2,30	5,40	18,50	15,50	13,00	15,30	60,3	60,2	200	520	520	820	820
Slow speed (1/30)	-	4,20	15,50	13,00	15,50	13,00	48,2	48,2	200	440	440	980	980

### VIBRATIONS

CHIARAVALLI jacks, with threaded spindle, are absolutely IRREVERSIBLE, special braking systems to maintain the set position are not required. If they should be subjected to high vibrations, we do suggest to brake the input shaft (for example by using a self-braking electric motor).



## MANUAL HANDLING

All CHIARAVALLI screw jacks can be operated manually. The following table shows the maximum load, assuming that a 250 mm diameter wheel is put at input jack to and 5 Kg force is applied to that wheel. Higher loads can be obtained by inserting a CHIARAVALLI gear box between the wheel and the jack or by increasing the wheel diameter.

### Lifting weights with manual operations

SIZE	CHS 1 daN	CHS 2 daN	CHS 3 daN	CHS 4 daN	CHS 5 daN	CHS 6 daN	CHS 7 daN	CHS 8 daN	CHS 9 daN	CHS 10 daN	CHS 12 daN	CHS 14 daN	CHS 16 daN
Fast speed (1/5)	500	1000	2000	1500	1000	950	900	860	-	-	-	-	-
Normal speed (1/10-1/20)	500	1000	2500	2900	2000	1800	1600	1500	-	-	-	-	-
Slow speed (1/30)	-	1000	2500	5000	4300	3800	3200	3200	-	-	-	-	-

## DRIVE BY ELECTRIC MOTOR

CHIARAVALLI series of screw jacks is provided for the connection with electric motors. The tables from pages 20 to 71 define the engine power and the torque at the start-up of dynamic load, the reduction ratio and the linear speed, related to a use of 30% out of 10 minutes of operation.

## MECHANICAL EFFICIENCY

The mechanical efficiency is shown in the table on pages 20 - 71. In the assembly of several jacks, to calculate the total efficiency of the transmission, it should be considered a decrease of 5% performance by each screw jack, for example:

- 2 jacks 95%
- 3 jacks 90% etc.. etc..

## HEATING

CHIARAVALLI screw jack, being an IRREVERSIBLE machine, has a relatively low mechanical efficiency, so a certain amount of installed power will turn into heat, bringing the jack, if used correctly, to a maximum temperature of 80 ° C.

## LOAD

From the tables on pages 20 - 71 you can detect the maximum loads for each screw jack not to be exceeded. To select the jack, it is necessary to apply also the coefficients stated below, relating to temperature and duty cycle. If different from the calculation conditions, they can change the actual load. Also check the maximum buckling load from the table on page 18, which changes according to the length of the lifting screw.



## GENERAL FEATURES

### OPERATING TEMPERATURE

All data mentioned in this catalogue refer to a room temperature of 20° C. For different room temperatures it is necessary to derive the correction "x" factor from the table here below. For the JACK CORRECT CAPACITY, multiply the jack load capacity by then "x" factor.

ROOM TEMPERATURE	10°	20°	30°	40°	50°	60°	70°	80°
"X" Factor	1,25	1	0,8	0,7	0,5	0,3	0,2	0,1

### OPERATION - SERVICE FACTOR

The tables on pages 22 - 36 refer to a service of 30% in 10 minutes and at a room temperature of 20° C. For different services, it is necessary to find the "SF" Service Factor relating to the service required by consulting the chart here below and multiplying the dynamic load factor such factor.

% OUT OF 10 MINUTES	30%	40%	50%	60%	70%	80%	90%	100%
"SF" Factor	1	1,1	1,3	1,6	2	2,5	3	5

### POWER AND INPUT TORQUE

See the tables from page 20 to page 71: for the boxes with a light blue background consult our technical department.



### LUBRICATION

CHIARAVALLI screw jacks are lubricated with a long life lithium soap grease AGIP GR MU EP2 and fitted with grease lubricator, for subsequent operations.

#### LUBRICATION INTERVALS:

normal working conditions: once a month  
heavy work conditions: once a week  
continuous working conditions: foresee lubrication system.

#### LUBRICATION OIL (OPTIONAL)

On request, it is possible to have oil lubrication.

Here below the recommended types of oil:

MOBIL	GEAR 630
SHELL	OMALA 220
IP	MELLANA 220

#### LUBRIFICATION LIFTING SCREW

A correct life of CHIARAVALLI screw jack also depends on the lifting screw good lubrication, which must be carried out not later than approximately 500 hours of normal working. Heavy duty or special environmental conditions reduce this lubrication interval.

The recommended lubricants for this operation are:

***ROTHEN 2000/P SPECIAL - KLUBER STRUCTOVIS CHD***  
***TOTAL CERAN WR2 - BECHEM-RHUS BERUTOX M 21 KN***

### USE ISTRUCTION

**STROKE** - 2000 mm maximum standard stroke  
Longer strokes are made on request.

**SPEED** - the linear speed that can be used by screw jacks depends on several factors:  
TYPE OF SCREW JACK and transmission ratio

THERMAL CAPACITY  
DYNAMIC LOAD  
ROOM TEMPERATURE  
SERVICE

The tables on pages 20 - 71 define, according to the load, the power required torque and the speed limit.



## CRITICAL COMPRESSION LOAD

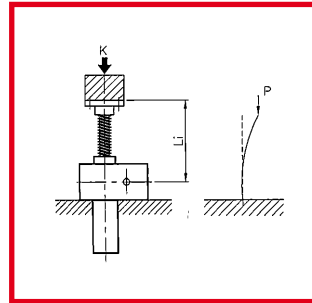

**EULERO 1**

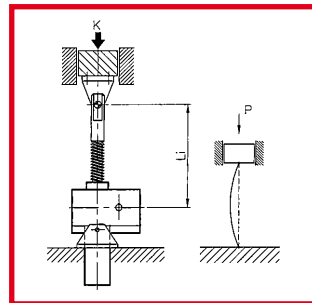

**EULERO 2**

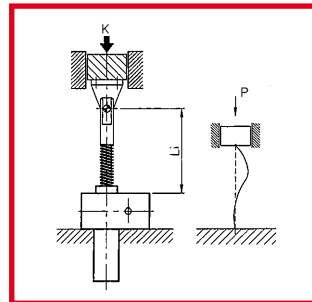

**EULERO 3**

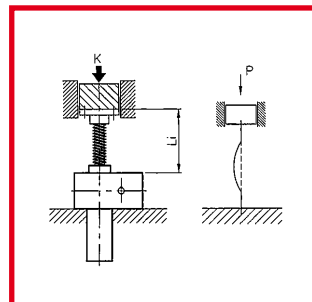

**EULERO 4**

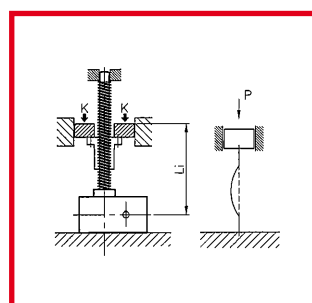

**EULERO 4**

SIZE			
Deflection length (mm)			
Eulero 1	Eulero 2	Eulero 3	Eulero 4
100	200	285	400
125	250	355	500
150	300	425	600
175	350	495	700
200	400	565	800
225	450	635	900
250	500	710	1000
275	550	780	1100
300	600	850	1200
325	650	920	1300
350	700	990	1400
375	750	1060	1500
400	800	1130	1600
425	850	1200	1700
450	900	1275	1800
475	950	1345	1900
500	1000	1415	2000
525	1050	1485	2100
550	1100	1555	2200
575	1150	1625	2300
600	1200	1700	2400
625	1250	1770	2500
650	1300	1840	2600
675	1350	1910	2700
700	1400	1980	2800
725	1450	2050	2900
750	1500	2120	3000
775	1550	2200	3100
800	1600	2270	3200
825	1650	2340	3300
850	1700	2400	3400
875	1750	2475	3500
900	1800	2546	3600
925	1850	2620	3700
950	1900	2690	3800
975	1950	2760	3900
1000	2000	2830	4000
1050	2100	2970	4200
1100	2200	3110	4400
1150	2300	3110	4600
1200	2400	3400	4800
1250	2500	3540	5000
1300	2600	3680	5200



# GENERAL FEATURES

CHS 1	CHS 2	CHS 3	CHS 4	CHS 5	CHS 6	CHS 7	CHS 8	CHS 9	CHS 10	CHS 12	CHS 14	CHS 16
kN	kN	kN	kN	kN	kN	kN	kN	kN	kN	kN	kN	kN
5,00	10,00	25,00	50,00	100,00	150,00	200,00	250,00	300,00	400,00	600,00	800,00	1.000,00
5,00	10,00	25,00	50,00	100,00	150,00	200,00	250,00	300,00	400,00	600,00	800,00	1.000,00
5,00	10,00	25,00	50,00	100,00	150,00	200,00	250,00	300,00	400,00	600,00	800,00	1.000,00
5,00	10,00	25,00	50,00	100,00	150,00	200,00	250,00	300,00	400,00	600,00	800,00	1.000,00
5,00	10,00	25,00	50,00	100,00	150,00	200,00	250,00	300,00	400,00	600,00	800,00	1.000,00
4,00	7,10	25,00	50,00	100,00	150,00	200,00	250,00	300,00	400,00	600,00	800,00	1.000,00
3,30	5,80	25,00	50,00	100,00	150,00	200,00	250,00	300,00	400,00	600,00	800,00	1.000,00
2,75	4,80	22,80	50,00	100,00	150,00	200,00	250,00	300,00	400,00	600,00	800,00	1.000,00
2,30	4,00	19,40	50,00	100,00	150,00	200,00	250,00	300,00	400,00	600,00	800,00	1.000,00
2,00	3,40	16,50	50,00	100,00	150,00	200,00	250,00	300,00	400,00	600,00	800,00	1.000,00
1,70	3,00	14,20	50,00	100,00	150,00	200,00	250,00	300,00	400,00	600,00	800,00	1.000,00
1,50	2,60	12,40	45,60	100,00	150,00	200,00	250,00	300,00	400,00	600,00	800,00	1.000,00
1,30	2,20	10,90	40,90	100,00	150,00	200,00	250,00	300,00	400,00	600,00	800,00	1.000,00
	2,00	9,60	36,20	100,00	150,00	200,00	250,00	300,00	400,00	600,00	800,00	1.000,00
	1,80	8,60	32,30	100,00	150,00	200,00	250,00	300,00	400,00	600,00	800,00	1.000,00
	1,60	7,80	29,00	100,00	150,00	200,00	250,00	300,00	400,00	600,00	800,00	1.000,00
	1,40	7,00	26,10	97,40	150,00	200,00	250,00	300,00	400,00	600,00	800,00	1.000,00
		6,30	23,80	90,80	150,00	200,00	250,00	300,00	400,00	600,00	800,00	1.000,00
		5,80	21,60	84,10	150,00	200,00	250,00	300,00	400,00	600,00	800,00	1.000,00
		5,30	19,80	77,40	85,20	200,00	250,00	300,00	400,00	600,00	800,00	1.000,00
		4,80	18,10	71,00	78,10	200,00	250,00	300,00	400,00	600,00	800,00	1.000,00
		4,50	16,80	65,50	72,00	200,00	250,00	300,00	400,00	600,00	800,00	1.000,00
		4,10	15,50	60,50	66,60	200,00	250,00	300,00	400,00	600,00	800,00	1.000,00
		3,80	14,40	56,10	61,70	200,00	250,00	300,00	400,00	600,00	800,00	1.000,00
		3,60	13,30	52,20	57,40	200,00	250,00	300,00	400,00	600,00	800,00	1.000,00
			12,50	48,60	53,50	200,00	250,00	300,00	400,00	600,00	800,00	1.000,00
			11,60	45,50	50,00	200,00	250,00	300,00	400,00	600,00	800,00	1.000,00
			10,90	42,60	46,85	200,00	250,00	300,00	400,00	600,00	800,00	1.000,00
			10,20	40,00	44,00	200,00	250,00	300,00	400,00	600,00	800,00	1.000,00
			9,60	37,60	41,40	200,00	250,00	300,00	400,00	600,00	800,00	1.000,00
			9,00	35,40	39,00	200,00	250,00	300,00	400,00	600,00	800,00	1.000,00
			8,50	33,40	36,80	200,00	250,00	300,00	400,00	600,00	800,00	1.000,00
			8,00	31,60	34,80	200,00	250,00	300,00	400,00	600,00	800,00	1.000,00
			7,60	29,90	32,90	200,00	250,00	300,00	400,00	600,00	800,00	1.000,00
			7,20	28,30	31,10	200,00	250,00	300,00	400,00	600,00	800,00	1.000,00
			6,90	26,90	29,60	177,51	250,00	277,50	400,00	600,00	800,00	1.000,00
			6,60	25,60	28,20	151,71	250,00	250,70	398,70	600,00	800,00	1.000,00
				23,20	25,50	129,35	244,59	230,00	394,00	600,00	800,00	1.000,00
				21,10	23,20	109,84	234,32	210,00	387,50	581,20	800,00	1.000,00
				19,30	21,30	92,72	199,62	190,00	359,70	539,50	800,00	1.000,00
				17,80	19,60	77,61	162,93	177,60	330,00	495,50	800,00	1.000,00
				16,40	18,00	64,21	130,56	164,20	304,00	457,00	776,50	1.000,00
				15,10	16,60	52,27	101,85	152,00	281,50	422,50	752,70	1.000,00

GENERAL FEATURES - CRITICAL COMPRESSION LOAD



# SERIES CHS 1 TS

# TRANSLATING SCREW

SERIES CHS 1 TS - 500 daN · TPN 18x4

SCREW JACK MODEL		CHS 1
LOAD	daN (Kg)	500
TPN SCREW	DIAMETER mm	18
	PITCH mm	4
GEAR RATIOS	FAST SPEED	5:1
	NORMAL SPEED	20:1
STROKE FOR INPUT REV.	FAST SPEED	0,80
	NORMAL SPEED	0,20
EFFICIENCY	FAST SPEED	25,5%
	NORMAL SPEED	23,8%
JACK WEIGHT (Kg)		2,4
SCREW WEIGHT TPN X 100 mm (Kg)		0,16
CASE MATERIAL		G25
GREASE QTY (Kg)		0,06
GREASE TYPE	AGIP GR MU EP2	
OPERATING TEMPERATURE	-5° C +80° C	

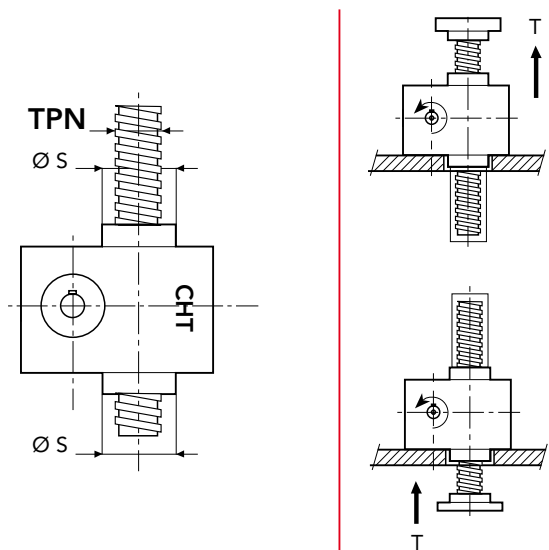
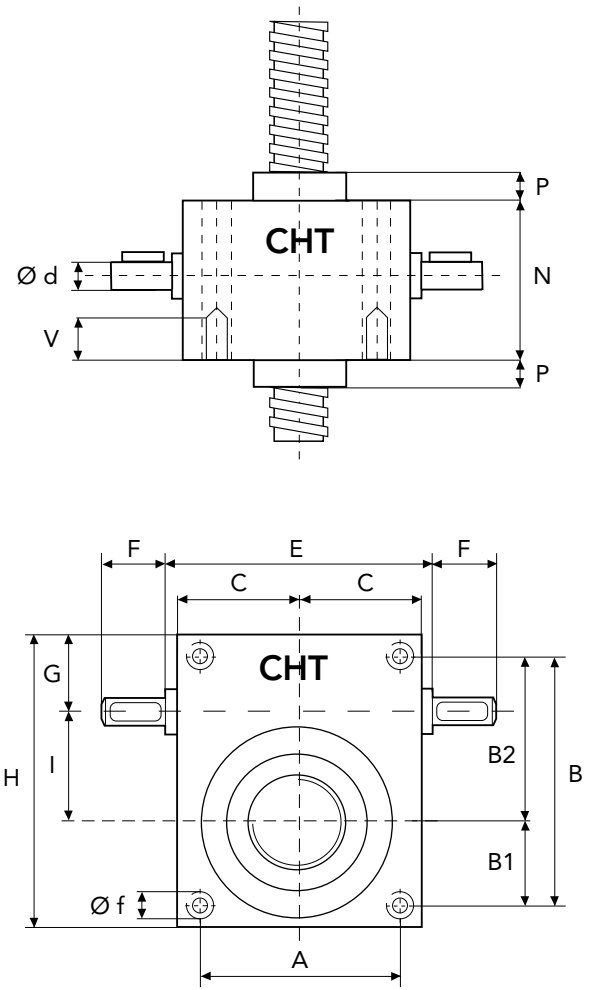

	A	B	B1	B2	C	E	F	G	H
CHS1	56	80	28	52	36	78	20	30	96
	I	N	P	P1	V	Ø d	Ø f	Ø s	TPN
CHS1	30	50	10	15	*	9	8,4	30	18x4

\* tapped holes on request

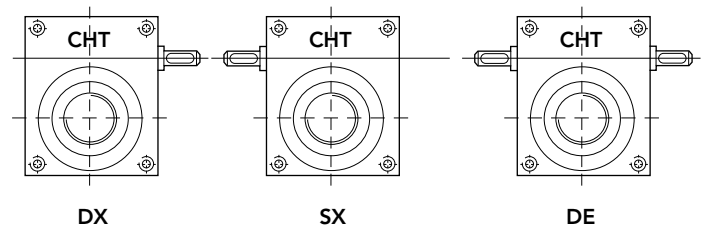

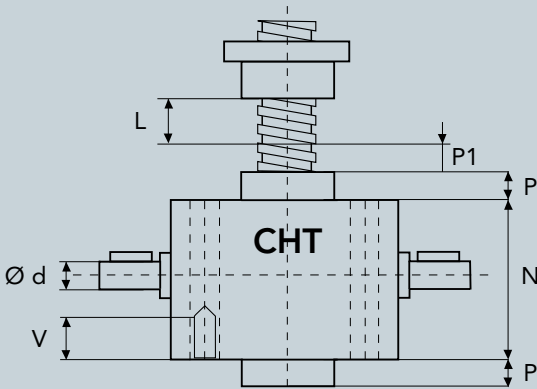

L = CORSA

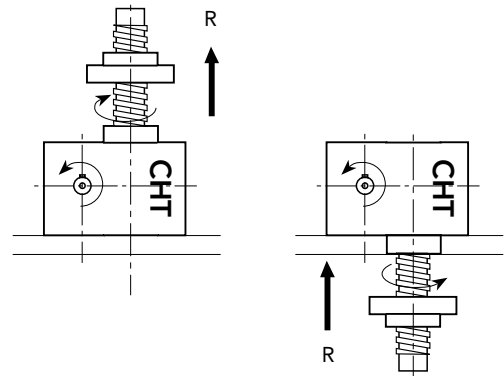
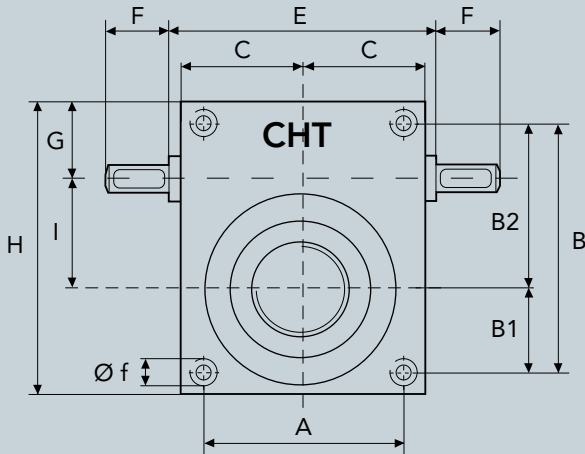
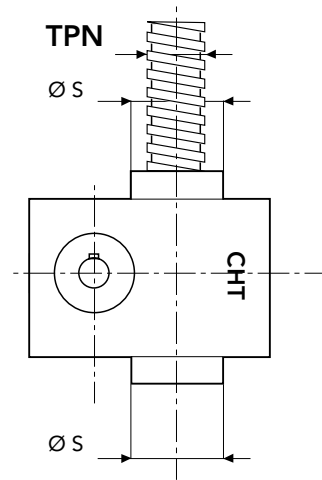

SERIES CHS 1 RS - 500 daN · TPN 18x4

## BRONZE NUT

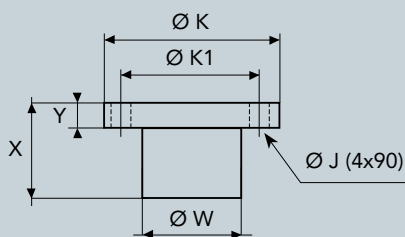

## PAM DIMENSIONS FOR BELL AND COUPLING

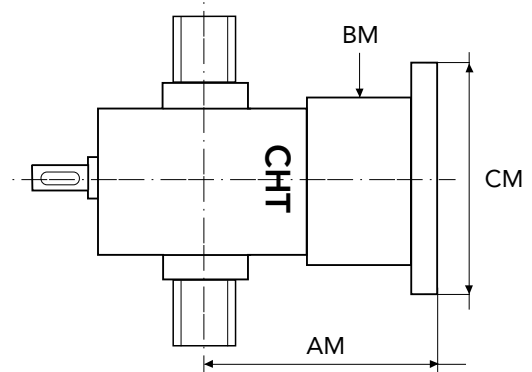

	X	Y	Ø W	Ø K	Ø K1	Ø J
CHS1	45	12	26	54	40	7

MOTOR	FLANGE TYPE	CM	AM	BM
GR. 56	B5	120	94	49
	B14	80		
GR. 63	B5	140	94	49
	B14	90		

## CONFIGURATION

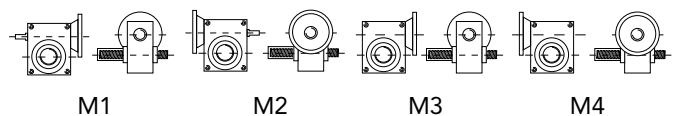



# SCREW JACK PERFORMANCE CHS 1

SCREW JACK PERFORMANCE SERIES CHS 1

## SCREW-JACKS WITH BALL SCREWS FOR TRANSLATING SCREW BY INTEGRATED NUT

load daN			500		300		100		50	
ratio	lifting speed mm	input speed	Pn Kw	Mt daNm	Pn Kw	Mt daNm	Pn Kw	Mt daNm	Pn Kw	Mt daNm
5	1200	1500	0,39	0,25	0,24	0,15	0,08	0,05	0,07	0,04
	800	1000	0,26	0,25	0,16	0,15	0,07	0,05	0,07	0,04
	600	750	0,20	0,25	0,12	0,15	0,07	0,05	0,07	0,04
	40	50	0,07	0,25	0,07	0,15	0,07	0,05	0,07	0,04

load daN			500		300		100		50	
ratio	lifting speed mm	input speed	Pn Kw	Mt daNm	Pn Kw	Mt daNm	Pn Kw	Mt daNm	Pn Kw	Mt daNm
20	300	1500	0,11	0,07	0,07	0,04	0,07	0,04	0,07	0,04
	200	1000	0,07	0,07	0,07	0,04	0,07	0,04	0,07	0,04
	150	750	0,07	0,07	0,07	0,04	0,07	0,04	0,07	0,04
	10	50	0,07	0,07	0,07	0,04	0,07	0,04	0,07	0,04



# CHS 1

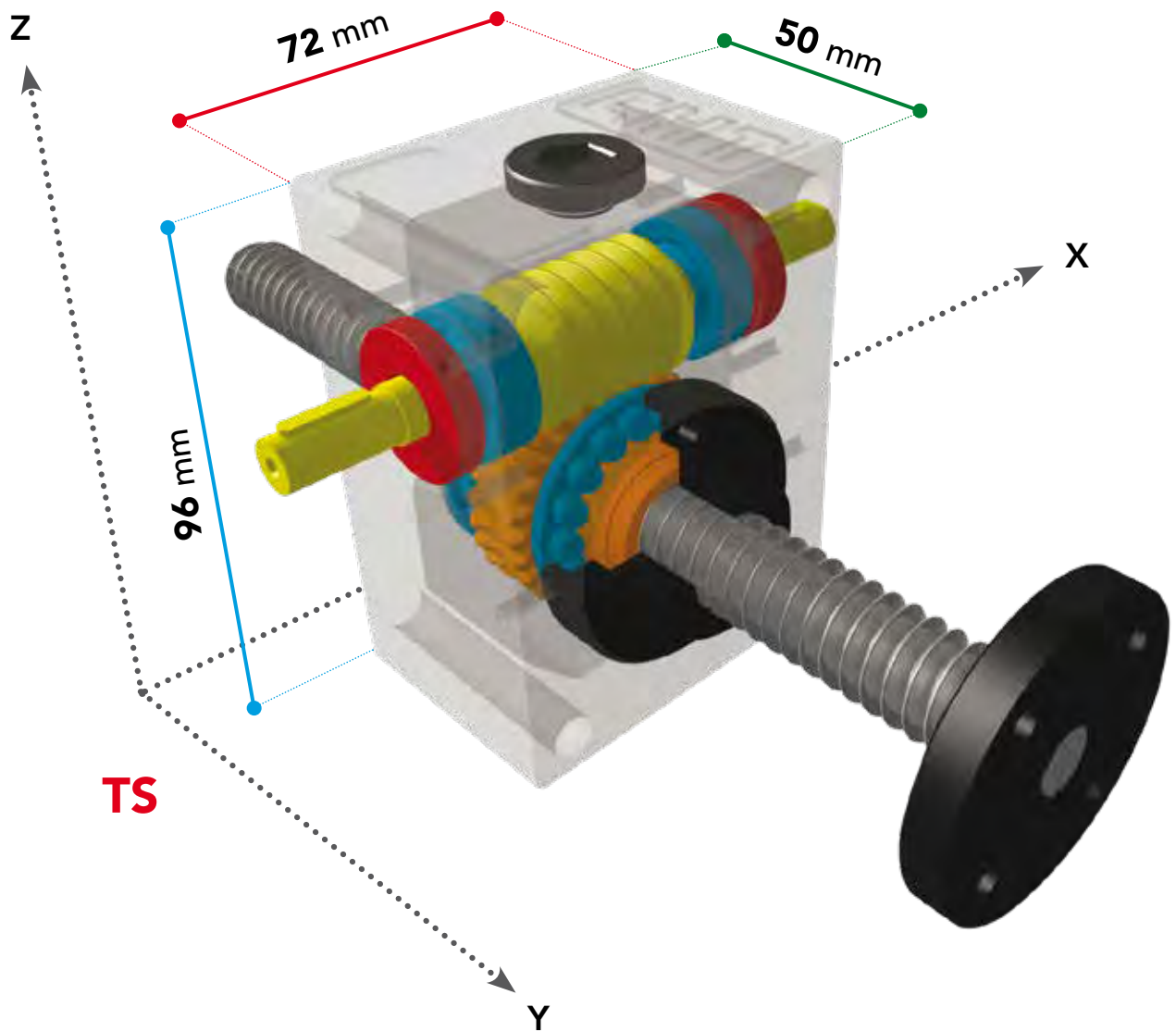

**TS**

**RS**



# SERIES CHS 2 TS

# TRANSLATING SCREW

SERIES CHS 2 TS - 1000 daN · TPN 20x4

SCREW JACK MODEL		CHS 2
LOAD	daN (Kg)	1000
TPN SCREW	DIAMETER mm PITCH mm	20 4
GEAR RATIOS	FAST SPEED NORMAL SPEED SLOW SPEED	5:1 10:1 30:1
STROKE FOR INPUT REV.	FAST SPEED NORMAL SPEED SLOW SPEED	0,80 0,40 0,13
EFFICIENCY	FAST SPEED NORMAL SPEED SLOW SPEED	24,8% 23,1% 21,5%
JACK WEIGHT (Kg)		4,0
SCREW WEIGHT TPN X 100 mm (Kg)		0,20
CASE MATERIAL		G25
GREASE QTY (Kg)		0,1
GREASE TYPE	AGIP GR MU EP2	
OPERATING TEMPERATURE	-5° C +80° C	

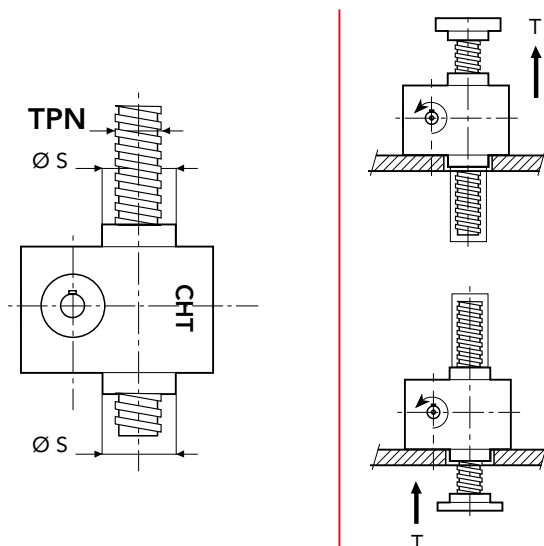
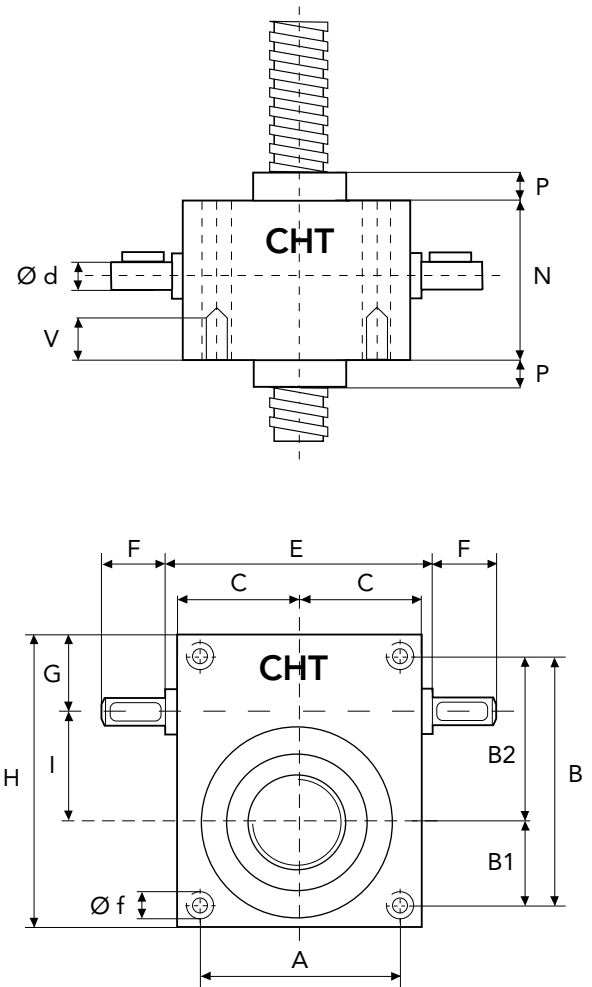

	A	B	B1	B2	C	E	F	G	H
CHS2	80	85	30	55	49	-	23,5	33,5	102
	I	N	P	P1	V	Ø d	Ø f	Ø s	TPN
CHS2	30	70	20	15	*	12	8,4	44	20x4

\* tapped holes on request

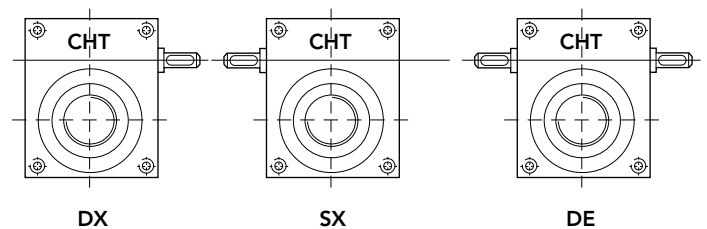

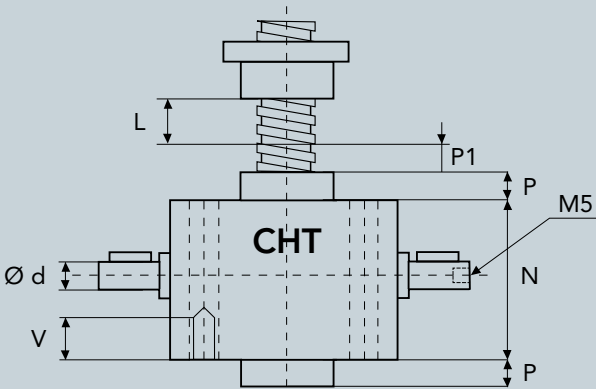

L = CORSA

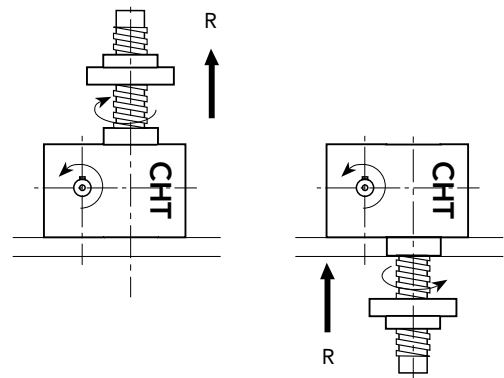
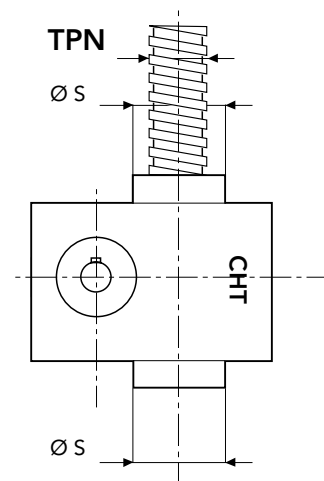
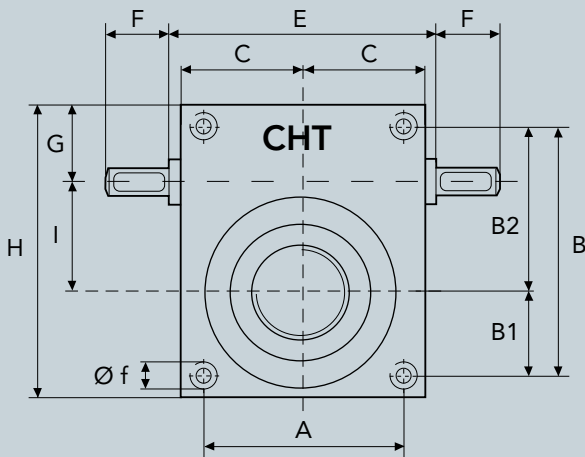

SERIES CHS 2 TS - 1000 daN · TPN 20x4

## BRONZE NUT

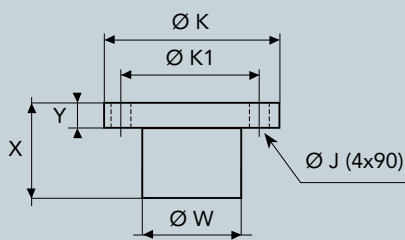

## MOTORS ADAPTORS FLANGES

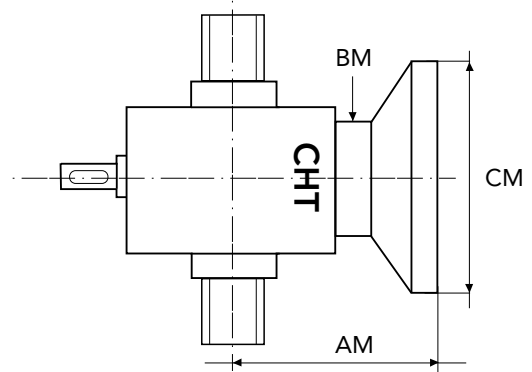

	X	Y	Ø W	Ø K	Ø K1	Ø J
CHS2	45	12	32	60	45	7

MOTOR	FLANGE TYPE	CM	AM	BM
GR. 63	B5	140	84	64
	B14	90		
GR. 71	B5	160	84	64
	B14	105		

## CONFIGURATION

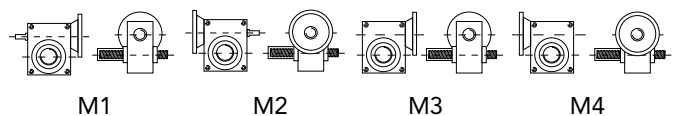



# SCREW JACK PERFORMANCE CHS 2

## SCREW-JACKS WITH BALL SCREWS FOR TRANSLATING SCREW BY INTEGRATED NUT

SCREW JACK PERFORMANCE SERIES CHS 2

load daN			1000		600		100		50	
ratio	lifting speed mm	input speed	Pn Kw	Mt daNm	Pn Kw	Mt daNm	Pn Kw	Mt daNm	Pn Kw	Mt daNm
5	1200	1500	0,81	0,51	0,49	0,31	0,24	0,15	0,08	0,05
	800	1000	0,54	0,51	0,32	0,31	0,16	0,15	0,07	0,05
	600	750	0,40	0,51	0,24	0,31	0,12	0,15	0,07	0,05
	40	50	0,07	0,51	0,07	0,31	0,07	0,15	0,07	0,05

load daN			1000		600		100		50	
ratio	lifting speed mm	input speed	Pn Kw	Mt daNm	Pn Kw	Mt daNm	Pn Kw	Mt daNm	Pn Kw	Mt daNm
10	600	1500	0,43	0,28	0,26	0,17	0,13	0,08	0,07	0,03
	400	1000	0,29	0,28	0,17	0,17	0,09	0,08	0,07	0,03
	300	750	0,22	0,28	0,13	0,17	0,07	0,08	0,07	0,03
	20	50	0,07	0,28	0,07	0,17	0,07	0,08	0,07	0,03

load daN			1000		600		100		50	
ratio	lifting speed mm	input speed	Pn Kw	Mt daNm	Pn Kw	Mt daNm	Pn Kw	Mt daNm	Pn Kw	Mt daNm
30	200	1500	0,16	0,10	0,09	0,06	0,07	0,03	0,07	0,01
	133	1000	0,10	0,10	0,07	0,06	0,07	0,03	0,07	0,01
	100	750	0,08	0,10	0,07	0,06	0,07	0,03	0,07	0,01
	6,7	50	0,07	0,10	0,07	0,06	0,07	0,03	0,07	0,01



# CHS 2

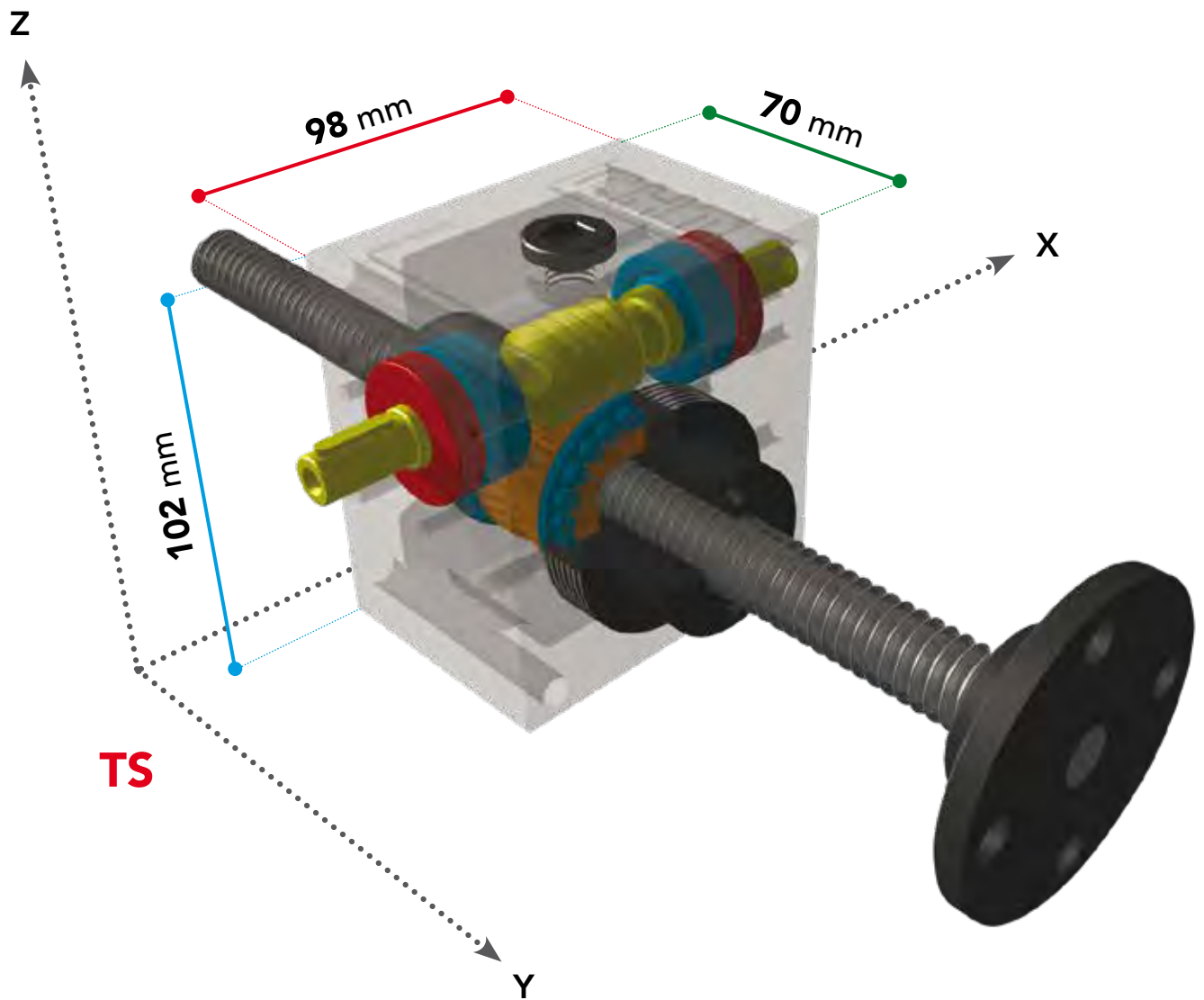



# SERIES CHS 3 TS

# TRANSLATING SCREW

SERIES CHS 3 TS - 2500 daN · TPN 30x6

SCREW JACK MODEL		CHS 3
LOAD	daN (Kg)	2500
TPN SCREW	DIAMETER mm PITCH mm	30 6
GEAR RATIOS	FAST SPEED NORMAL SPEED SLOW SPEED	5:1 10:1 30:1
STROKE FOR INPUT REV.	FAST SPEED NORMAL SPEED SLOW SPEED	1,20 0,60 0,20
EFFICIENCY	FAST SPEED NORMAL SPEED SLOW SPEED	22,5% 21,0% 19,5%
JACK WEIGHT (Kg)		9,0
SCREW WEIGHT TPN X 100 mm (Kg)		0,48
CASE MATERIAL		GJS 450
GREASE QTY (Kg)		0,3
GREASE TYPE	AGIP GR MU EP2	
OPERATING TEMPERATURE	-5° C +80° C	

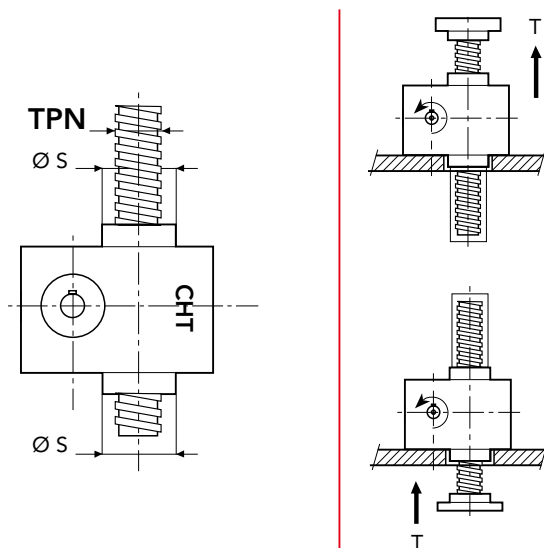
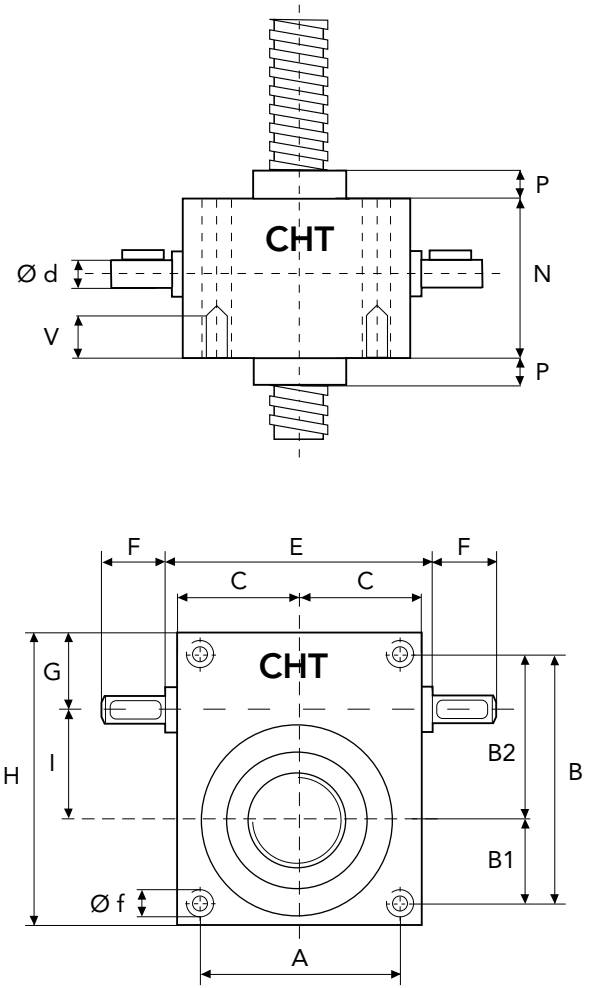

	A	B	B1	B2	C	E	F	G	H
CHS3	102	131	48	83	64	-	39	42,5	150
	I	N	P	P1	V	Ø d	Ø f	Ø s	TPN
CHS3	50	90	25	20	*	20	10,4	60	30x6

\* tapped holes on request

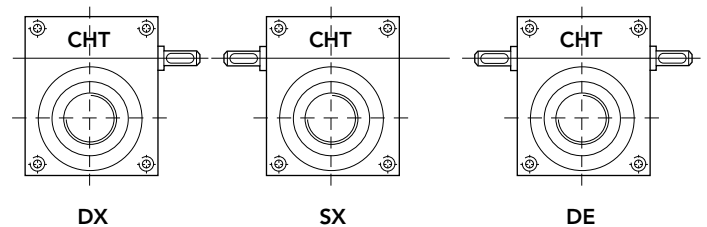



# SERIES CHS 3 RS

# ROTATING SCREW

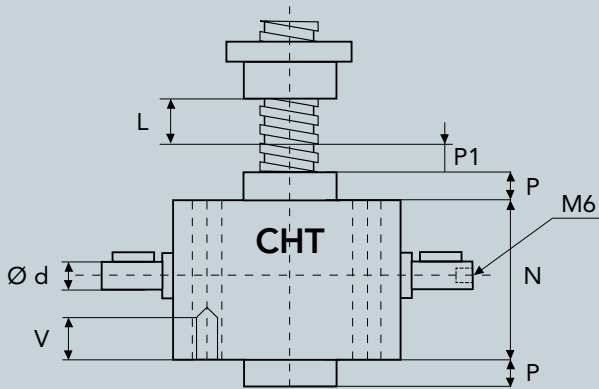

L = CORSA

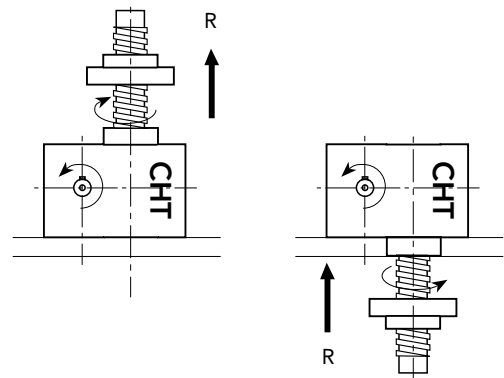
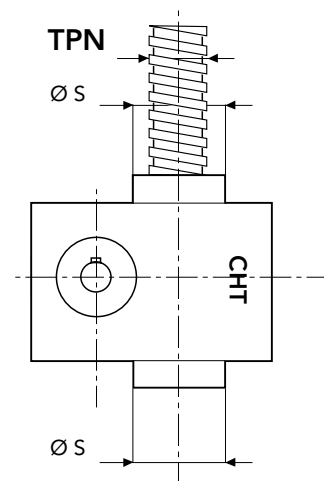
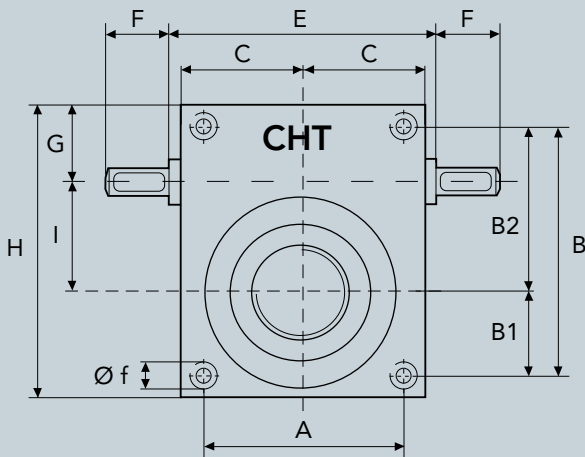

SERIES CHS 3 TS - 2500 daN · TPN 30x6

## BRONZE NUT

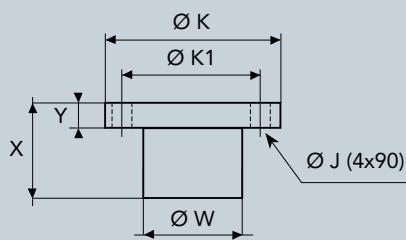

## MOTORS ADAPTORS FLANGES

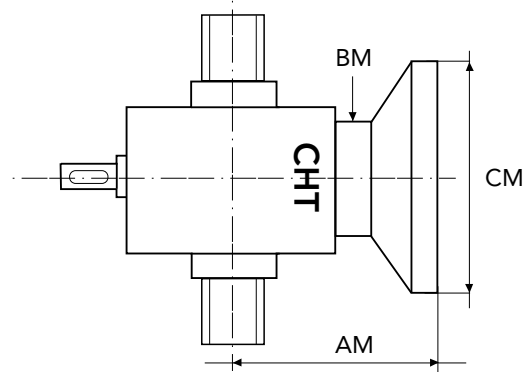

	X	Y	Ø W	Ø K	Ø K1	Ø J
CHS3	48	14	46	80	64	7

MOTOR	FLANGE TYPE	CM	AM	BM
GR. 63	B5	140		
GR. 71	B5	160	112,5	84
GR. 80	B5 B14	200 120		

## CONFIGURATION

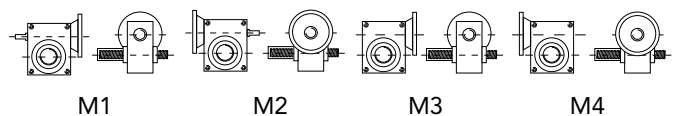



# SCREW JACK PERFORMANCE CHS 3

## SCREW-JACKS WITH BALL SCREWS FOR TRANSLATING SCREW BY INTEGRATED NUT

Consult our technical DPT

SCREW JACK PERFORMANCE SERIES CHS 3

load daN			2500		1500		750		250	
ratio	lifting speed mm	input speed	Pn Kw	Mt daNm	Pn Kw	Mt daNm	Pn Kw	Mt daNm	Pn Kw	Mt daNm
5	1800	1500	3,33	2,12	2,00	1,27	1,00	0,64	0,33	0,21
	1200	1000	2,22	2,12	1,33	1,27	0,67	0,64	0,22	0,21
	900	750	1,67	2,12	1,00	1,27	0,50	0,64	0,17	0,21
	60	50	0,11	2,12	0,07	1,27	0,07	0,64	0,07	0,21

load daN			2500		1500		750		250	
ratio	lifting speed mm	input speed	Pn Kw	Mt daNm	Pn Kw	Mt daNm	Pn Kw	Mt daNm	Pn Kw	Mt daNm
10	900	1500	1,79	1,14	1,07	0,68	0,54	0,34	0,18	0,11
	600	1000	1,19	1,14	0,71	0,68	0,36	0,34	0,12	0,11
	450	750	0,89	1,14	0,54	0,68	0,27	0,34	0,09	0,11
	30	50	0,07	1,14	0,07	0,68	0,07	0,34	0,07	0,11

load daN			2500		1500		750		250	
ratio	lifting speed mm	input speed	Pn Kw	Mt daNm	Pn Kw	Mt daNm	Pn Kw	Mt daNm	Pn Kw	Mt daNm
30	300	1500	0,64	0,41	0,38	0,24	0,19	0,12	0,07	0,04
	200	1000	0,43	0,41	0,26	0,24	0,13	0,12	0,07	0,04
	150	750	0,32	0,41	0,19	0,24	0,10	0,12	0,07	0,04
	10,0	50	0,07	0,41	0,07	0,24	0,07	0,12	0,07	0,04



# CHS 3

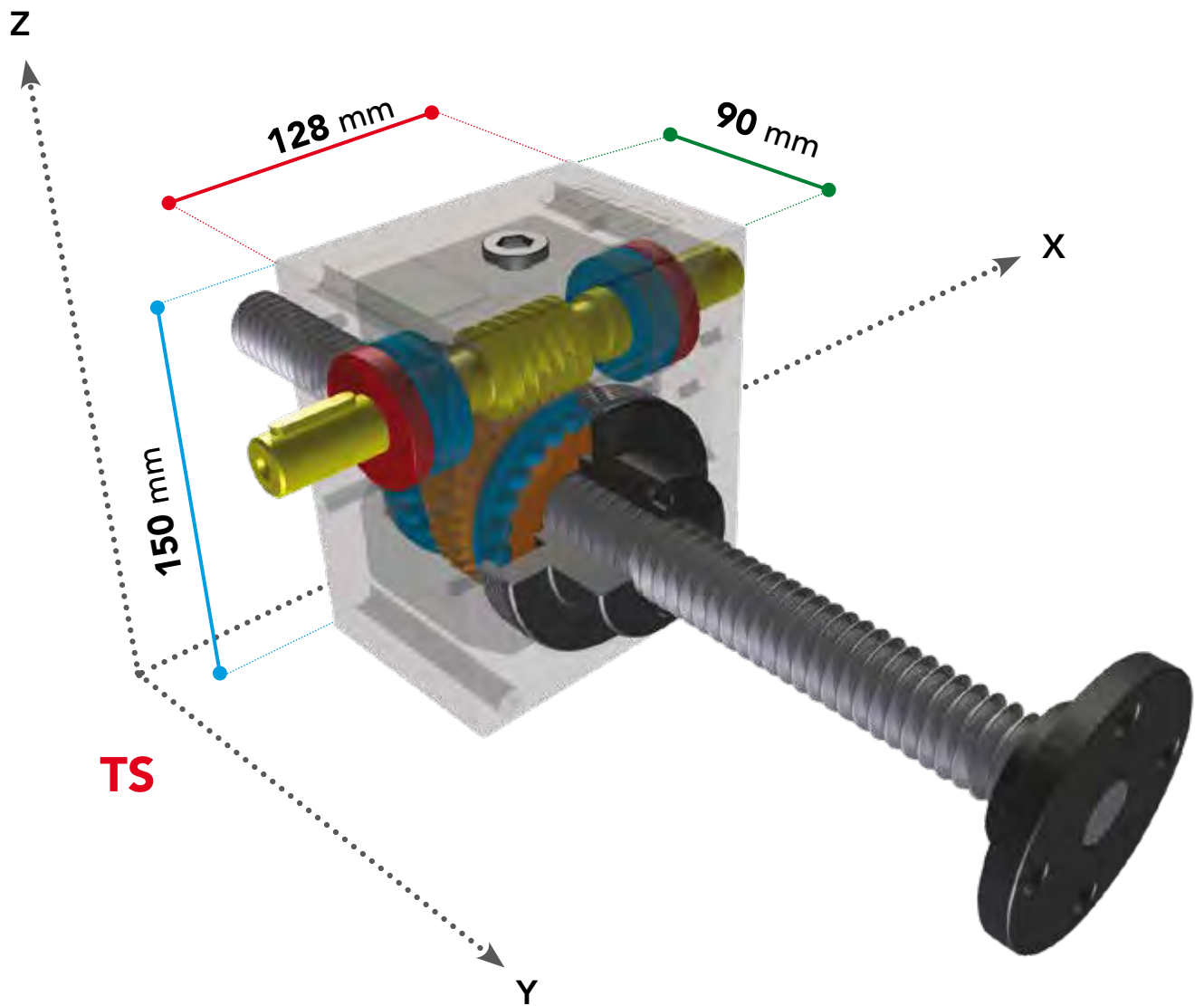

**TS**



**TS**

**RS**



# SERIES CHS 4 TS

# TRANSLATING SCREW

SERIES CHS 4 TS - 5000 daN · TPN 40x7

SCREW JACK MODEL		CHS 4
LOAD	daN (Kg)	5000
TPN SCREW	DIAMETER mm	40
	PITCH mm	7
GEAR RATIOS	FAST SPEED	5:1
	NORMAL SPEED	10:1
	SLOW SPEED	30:1
STROKE FOR INPUT REV.	FAST SPEED	1,40
	NORMAL SPEED	0,70
	SLOW SPEED	0,23
EFFICIENCY	FAST SPEED	21,0%
	NORMAL SPEED	19,6%
	SLOW SPEED	18,2%
JACK WEIGHT (Kg)		20
SCREW WEIGHT TPN X 100 mm (Kg)		0,9
CASE MATERIAL		GJS 450
GREASE QTY (Kg)		0,65
GREASE TYPE	AGIP GR MU EP2	
OPERATING TEMPERATURE	-5° C +80° C	

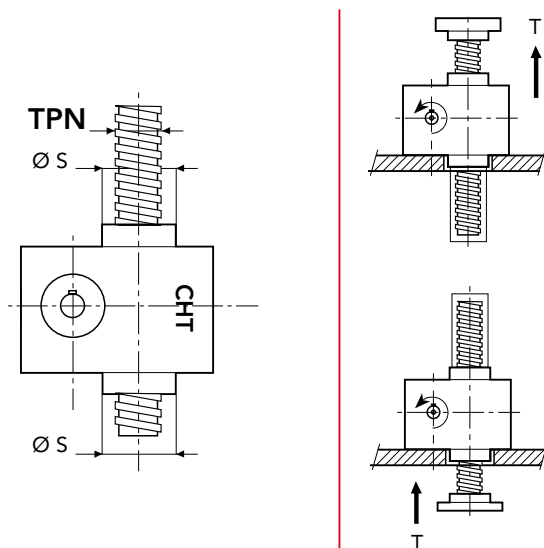
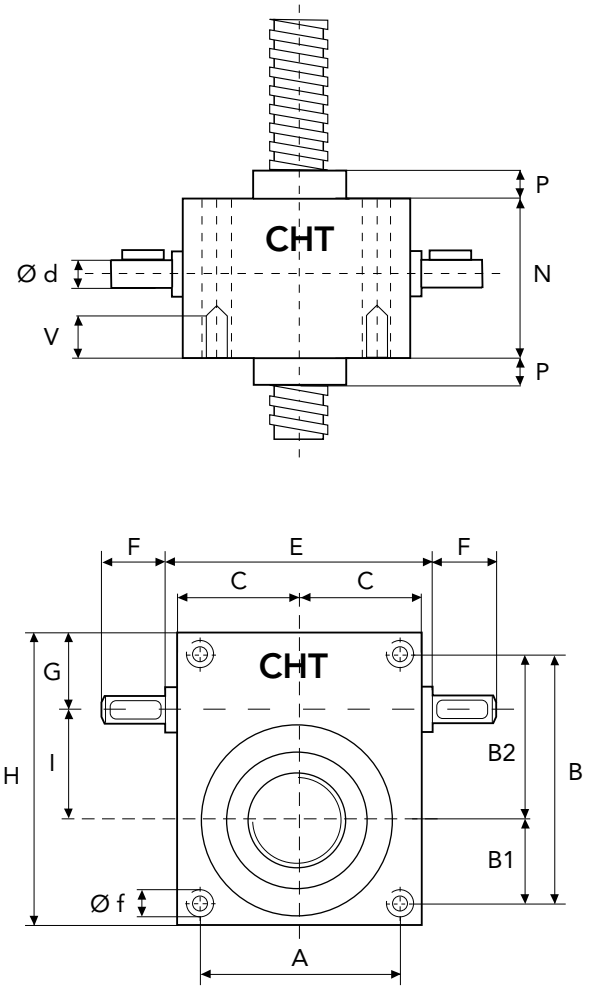

	A	B	B1	B2	C	E	F	G	H
CHS4	130	165	60	105	82,5	-	52,5	55	200
	I	N	P	P1	V	Ø d	Ø f	Ø s	TPN
CHS4	70	120	35	25	*	25	12,5	69	40x7

\* tapped holes on request

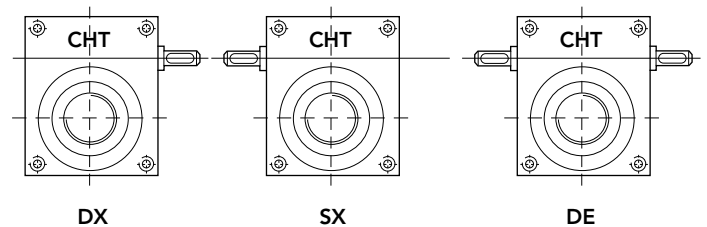

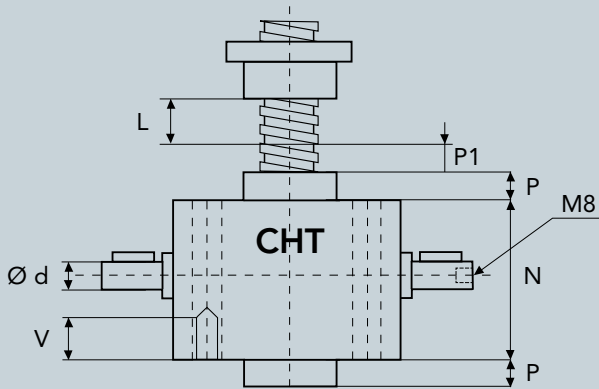

L = CORSA

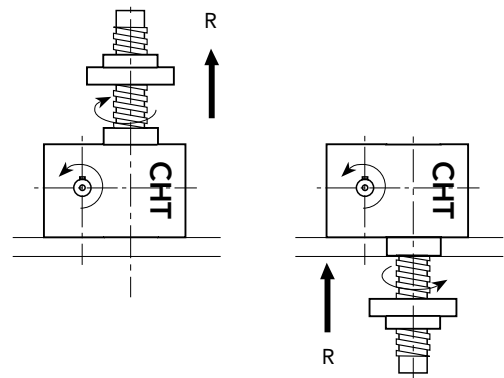
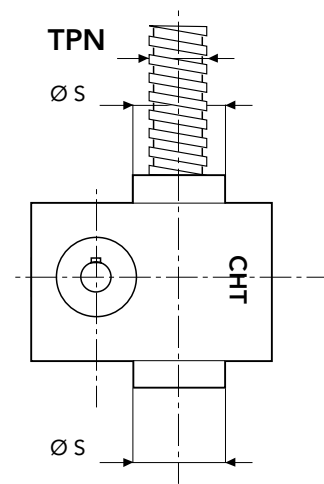
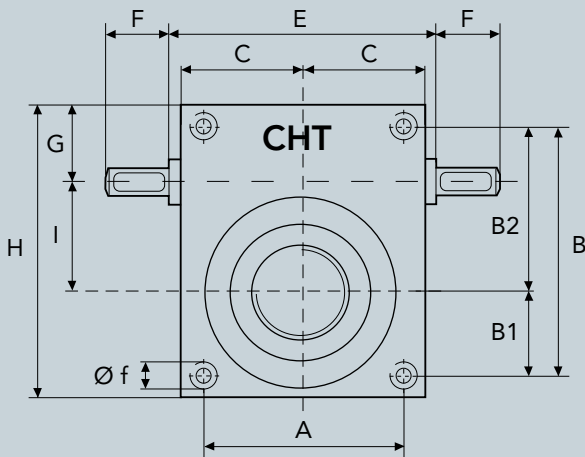

SERIES CHS 4 TS - 5000 daN · TPN 40x7

## BRONZE NUT

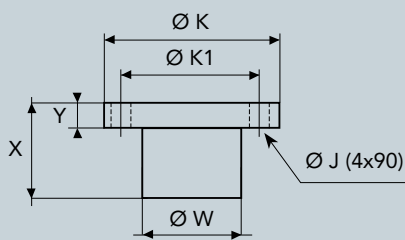

## MOTORS ADAPTORS FLANGES

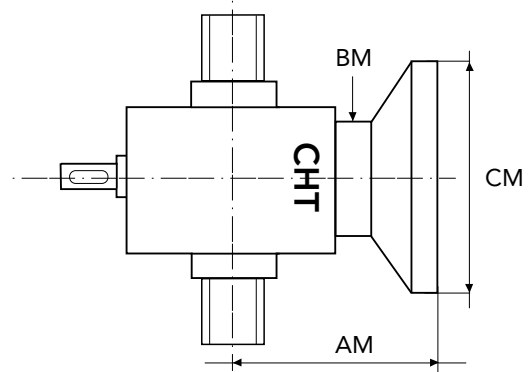

	X	Y	Ø W	Ø K	Ø K1	Ø J
CHS4	75	15	60	96	78	9

MOTOR	FLANGE TYPE	CM	AM	BM
GR. 80	B5	200	140	108
	B14	120		
GR. 90	B5	200	140	108
	B14	140		
GR. 100/112	B5	250	140	108
	B14	160		

## CONFIGURATION

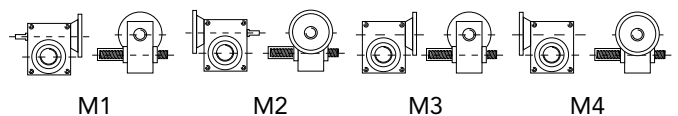



# SCREW JACK PERFORMANCE CHS 4

## SCREW-JACKS WITH BALL SCREWS FOR TRANSLATING SCREW BY INTEGRATED NUT

Consult our technical DPT

SCREW JACK PERFORMANCE SERIES CHS 4

load daN			5000		3000		1500		500	
ratio	lifting speed mm	input speed	Pn Kw	Mt daNm	Pn Kw	Mt daNm	Pn Kw	Mt daNm	Pn Kw	Mt daNm
5	2100	1500	8,34	5,31	5,00	3,18	2,50	1,59	0,83	0,53
	1400	1000	5,56	5,31	3,33	3,18	1,67	1,59	0,56	0,53
	1050	750	4,17	5,31	2,50	3,18	1,25	1,59	0,42	0,53
	70	50	0,28	5,31	0,17	3,18	0,08	1,59	0,07	0,53

load daN			5000		3000		1500		500	
ratio	lifting speed mm	input speed	Pn Kw	Mt daNm	Pn Kw	Mt daNm	Pn Kw	Mt daNm	Pn Kw	Mt daNm
10	1050	1500	4,47	2,84	2,68	1,71	1,34	0,85	0,45	0,28
	700	1000	2,98	2,84	1,79	1,71	0,89	0,85	0,30	0,28
	525	750	2,23	2,84	1,34	1,71	0,67	0,85	0,22	0,28
	35	50	0,15	2,84	0,09	1,71	0,07	0,85	0,07	0,28

load daN			5000		3000		1500		500	
ratio	lifting speed mm	input speed	Pn Kw	Mt daNm	Pn Kw	Mt daNm	Pn Kw	Mt daNm	Pn Kw	Mt daNm
30	350	1500	1,60	1,02	0,96	0,61	0,48	0,31	0,16	0,10
	233,3	1000	1,07	1,02	0,64	0,61	0,32	0,31	0,11	0,10
	175,0	750	0,80	1,02	0,48	0,61	0,24	0,31	0,08	0,10
	11,7	50	0,07	1,02	0,07	0,61	0,07	0,31	0,07	0,10



# CHS 4

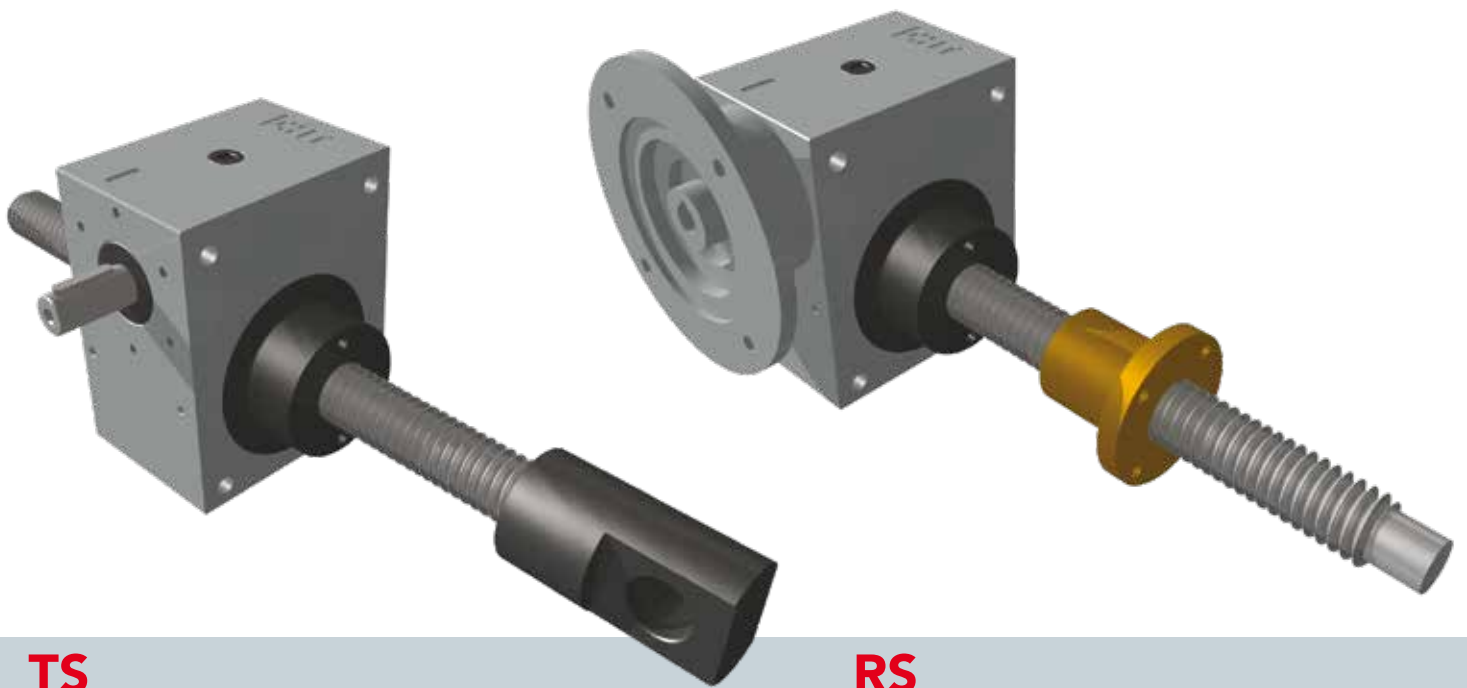
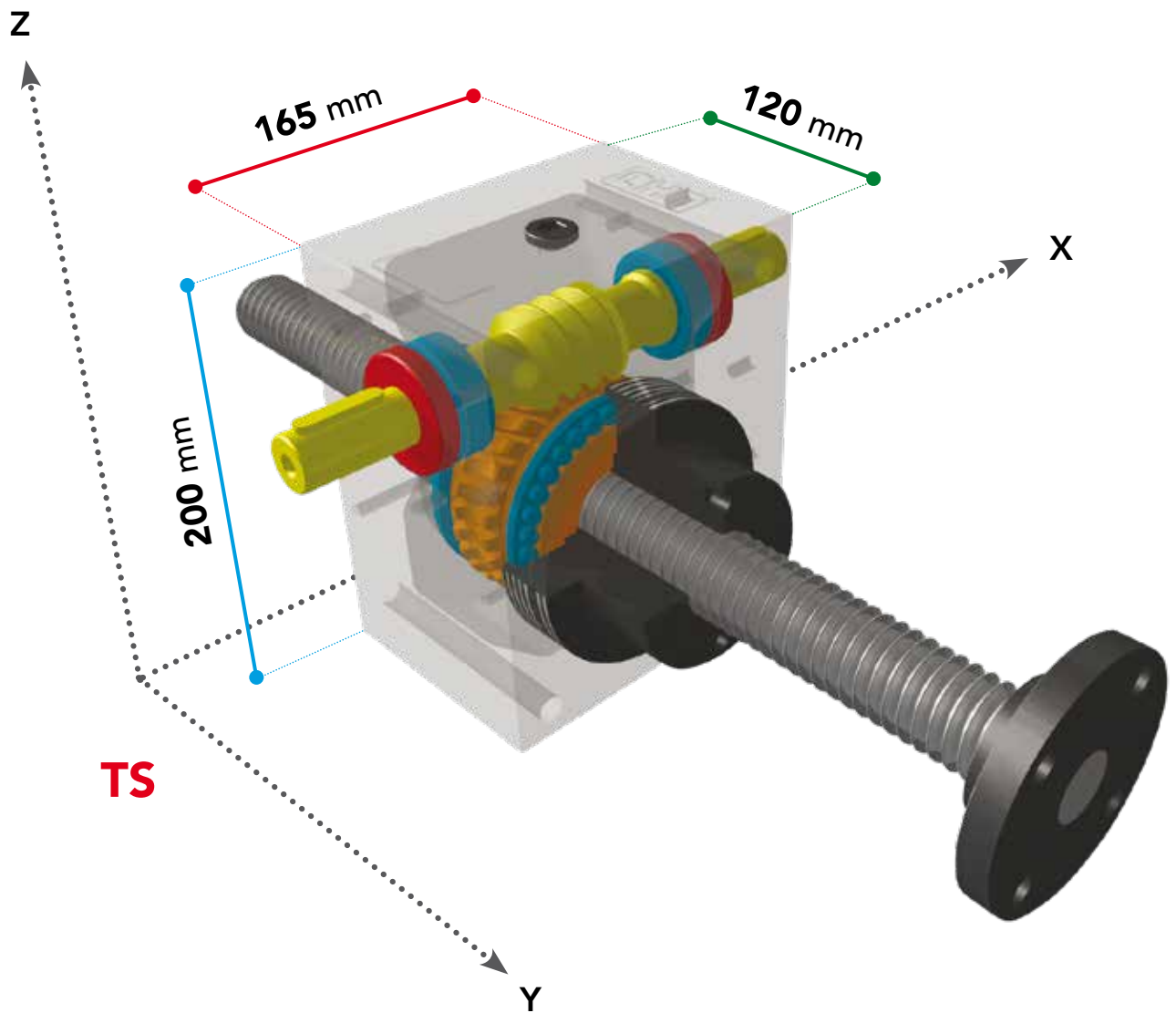



# SERIES CHS 5 TS

# TRANSLATING SCREW

SERIES CHS 5 TS - 10000 daN · TPN 55x9

SCREW JACK MODEL		CHS 5
LOAD	daN (Kg)	10000
TPN SCREW	DIAMETER mm	55
	PITCH mm	9
GEAR RATIOS	FAST SPEED	5:1
	NORMAL SPEED	10:1
	SLOW SPEED	30:1
STROKE FOR INPUT REV.	FAST SPEED	1,80
	NORMAL SPEED	0,90
	SLOW SPEED	0,30
EFFICIENCY	FAST SPEED	19,5%
	NORMAL SPEED	18,2%
	SLOW SPEED	16,9%
JACK WEIGHT (Kg)		27
SCREW WEIGHT TPN X 100 mm (Kg)		1,7
CASE MATERIAL		GJS 450
GREASE QTY (Kg)	1,0	
GREASE TYPE	AGIP GR MU EP2	
OPERATING TEMPERATURE	-5° C	
	+80° C	

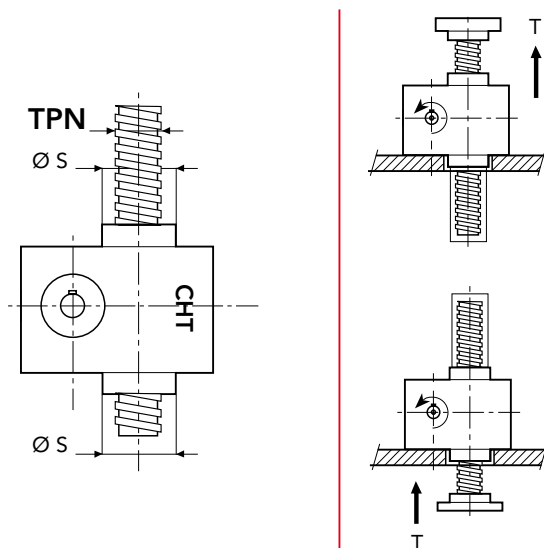
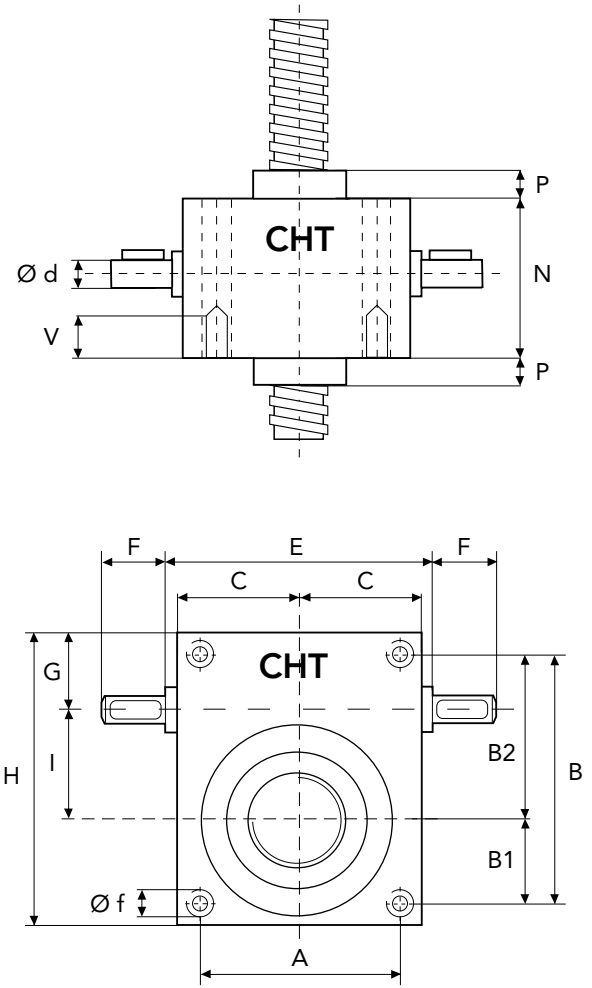

	A	B	B1	B2	C	E	F	G	H
CHS5	134	175	60	115	87,5	-	47,5	68	216
	I	N	P	P1	V	Ø d	Ø f	Ø s	TPN
CHS5	70	150	40	25	40	25	M20	90	55x9

\* tapped holes on request

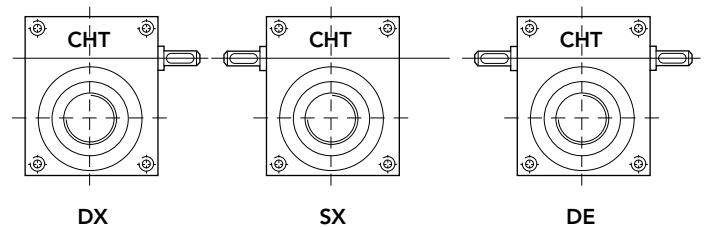

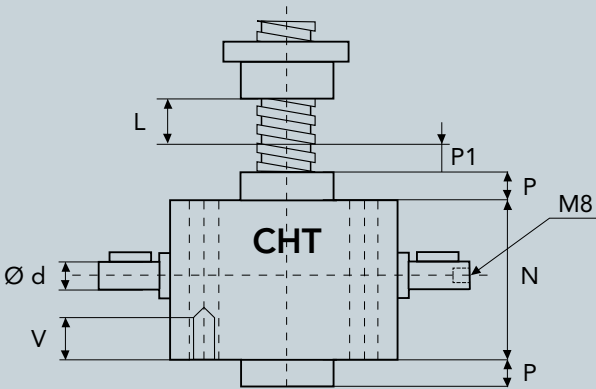

L = CORSA

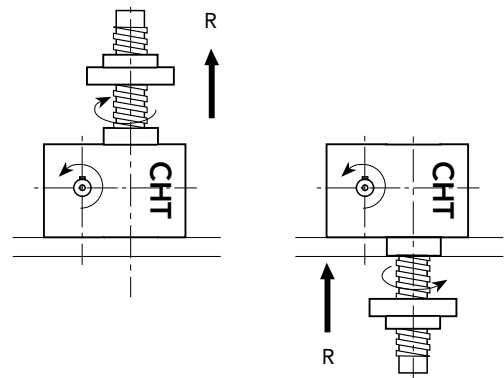
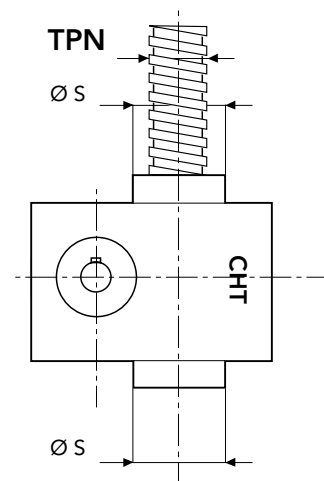
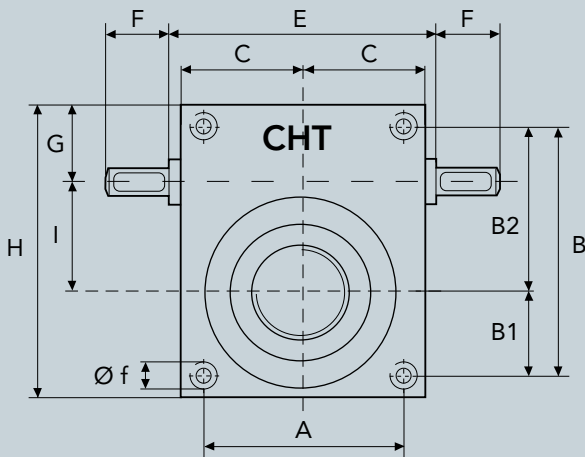

SERIES CHS 5 TS - 10000 daN · TPN 55x9

## BRONZE NUT

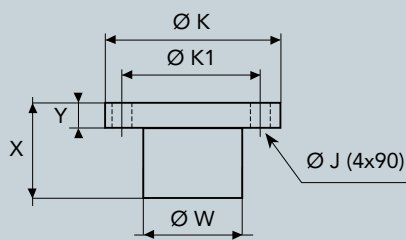

## MOTORS ADAPTORS FLANGES

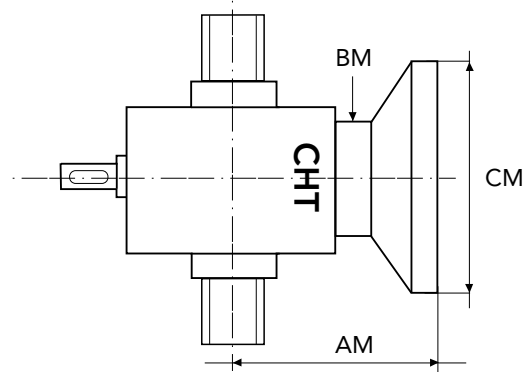

	X	Y	Ø W	Ø K	Ø K1	Ø J
CHS5	100	20	76	130	100	13

MOTOR	FLANGE TYPE	CM	AM	BM
GR. 80	B5	200	145	108
	B14	120		
GR. 90	B5	200	145	108
	B14	140		
GR. 100/112	B5	250	145	108
	B14	160		

## CONFIGURATION

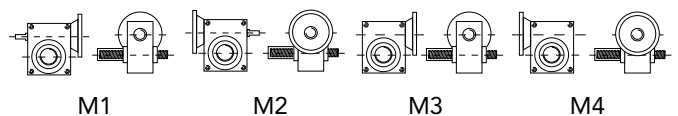



# SCREW JACK PERFORMANCE CHS 5

## SCREW-JACKS WITH BALL SCREWS FOR TRANSLATING SCREW BY INTEGRATED NUT

Consult our technical DPT

SCREW JACK PERFORMANCE SERIES CHS 5

load daN			10000		5000		3000		1000	
ratio	lifting speed mm	input speed	Pn Kw	Mt daNm	Pn Kw	Mt daNm	Pn Kw	Mt daNm	Pn Kw	Mt daNm
5	2700	1500	23,09	14,70	11,54	7,35	6,93	4,41	2,31	1,47
	1800	1000	15,39	14,70	7,70	7,35	4,62	4,41	1,54	1,47
	1350	750	11,54	14,70	5,77	7,35	3,46	4,41	1,15	1,47
	90	50	0,77	14,70	0,38	7,35	0,23	4,41	0,08	1,47

load daN			10000		5000		3000		1000	
ratio	lifting speed mm	input speed	Pn Kw	Mt daNm	Pn Kw	Mt daNm	Pn Kw	Mt daNm	Pn Kw	Mt daNm
10	1350	1500	12,37	7,87	6,18	3,94	3,71	2,36	1,24	0,79
	900	1000	8,25	7,87	4,12	3,94	2,47	2,36	0,82	0,79
	675	750	6,18	7,87	3,09	3,94	1,86	2,36	0,62	0,79
	45	50	0,41	7,87	0,21	3,94	0,12	2,36	0,07	0,79

load daN			10000		5000		3000		1000	
ratio	lifting speed mm	input speed	Pn Kw	Mt daNm	Pn Kw	Mt daNm	Pn Kw	Mt daNm	Pn Kw	Mt daNm
30	450	1500	4,44	2,83	2,22	1,41	1,33	0,85	0,44	0,28
	300	1000	2,96	2,83	1,48	1,41	0,89	0,85	0,30	0,28
	225	750	2,22	2,83	1,11	1,41	0,67	0,85	0,22	0,28
	15	50	0,15	2,83	0,07	1,41	0,07	0,85	0,07	0,28



# CHS 5

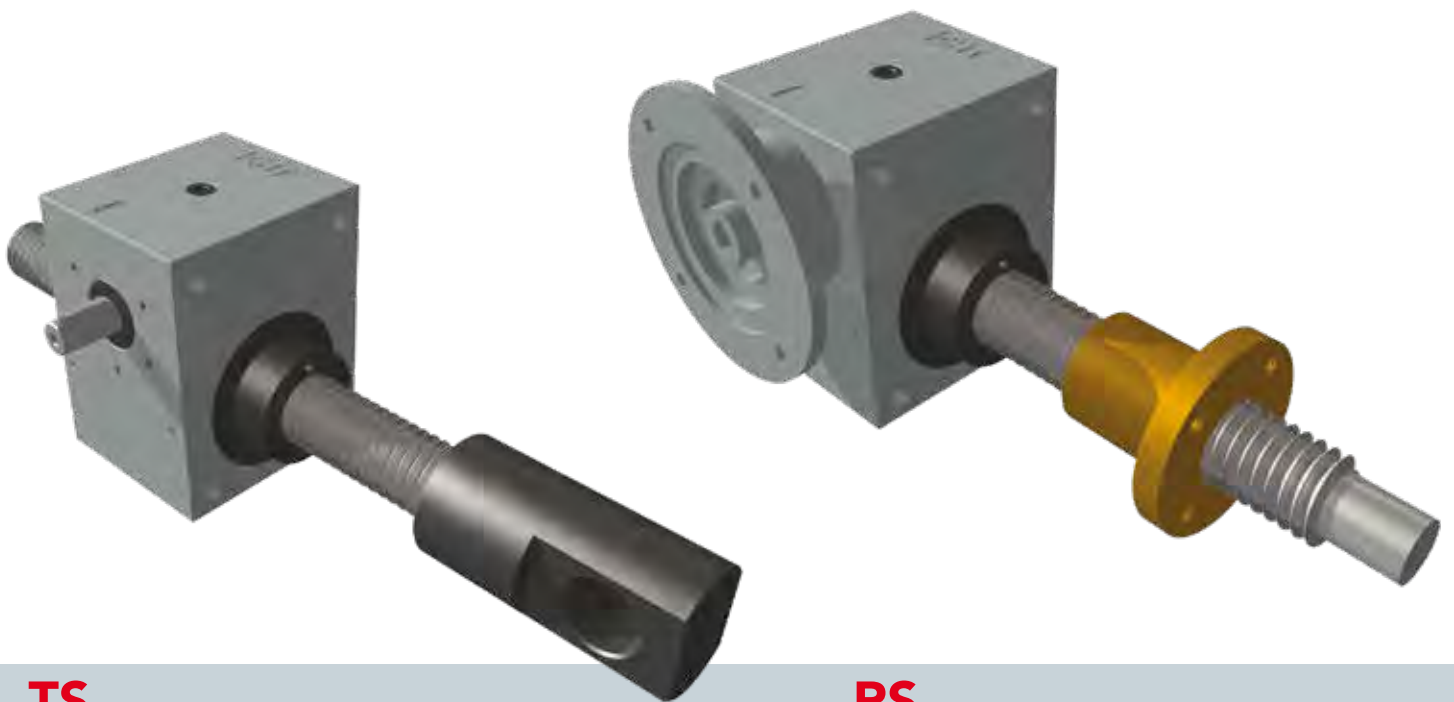
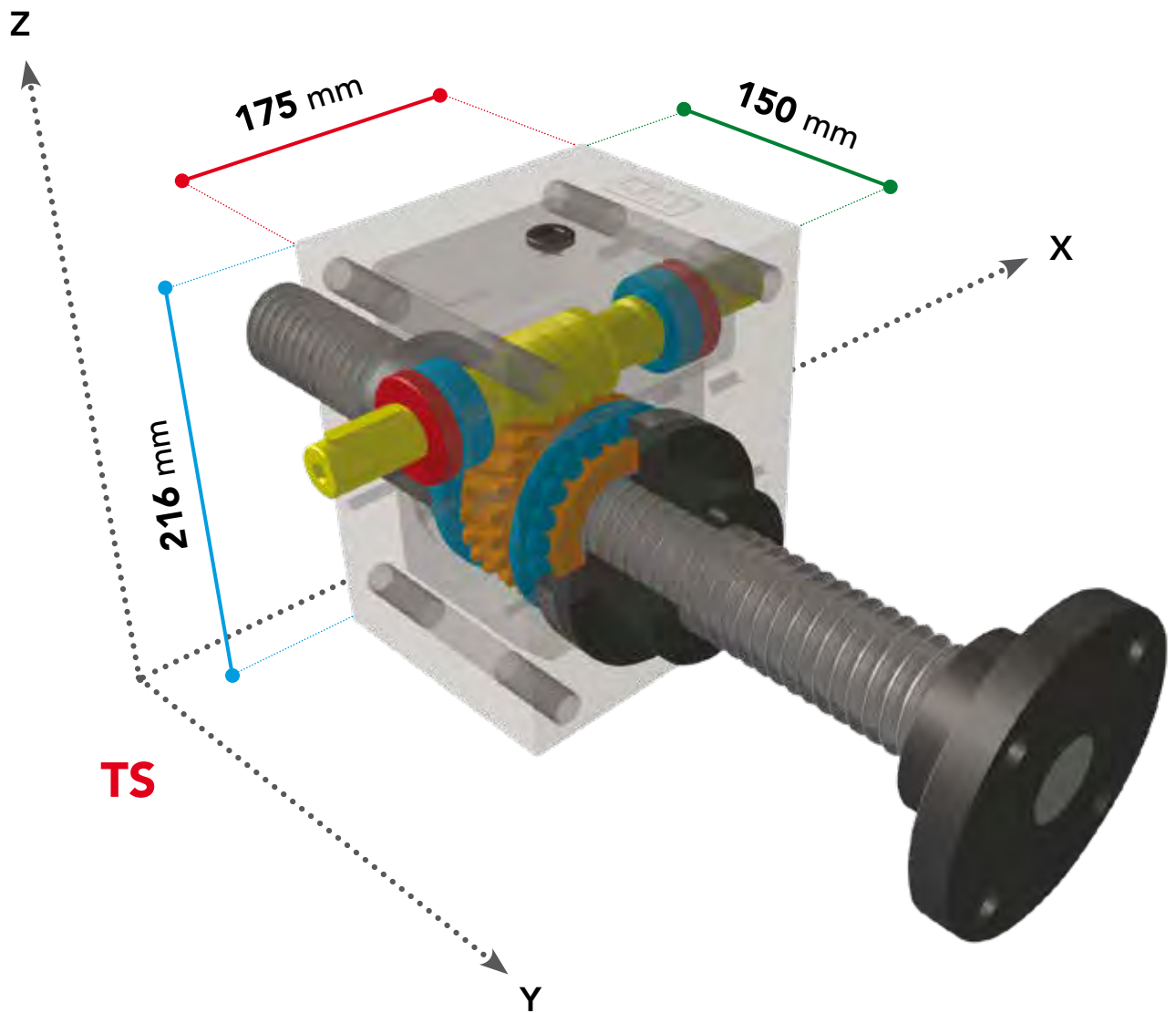



# SERIES CHS 6 TS

# TRANSLATING SCREW

SERIES CHS 6 TS - 15000 daN · TPN 60x9

SCREW JACK MODEL		CHS 6
LOAD	daN (Kg)	15000
TPN SCREW	DIAMETER mm PITCH mm	60 9
GEAR RATIOS	FAST SPEED NORMAL SPEED SLOW SPEED	5:1 10:1 30:1
STROKE FOR INPUT REV.	FAST SPEED NORMAL SPEED SLOW SPEED	1,80 0,90 0,30
EFFICIENCY	FAST SPEED NORMAL SPEED SLOW SPEED	19,3% 18,0% 16,5%
JACK WEIGHT (Kg)		29
SCREW WEIGHT TPN X 100 mm (Kg)		2
CASE MATERIAL		G25
GREASE QTY (Kg)		1
GREASE TYPE	AGIP GR MU EP2	
OPERATING TEMPERATURE	-5° C +80° C	

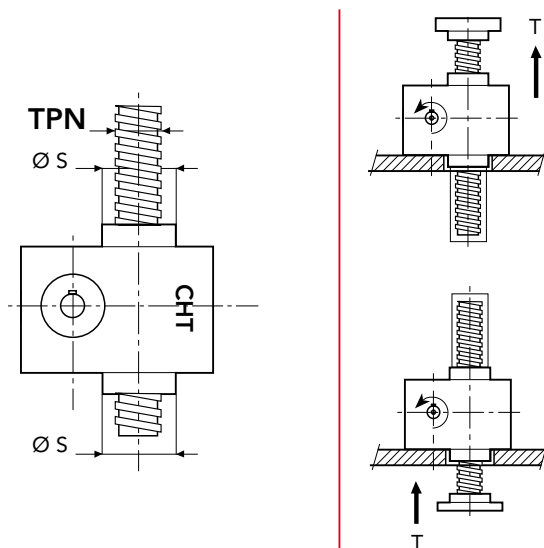
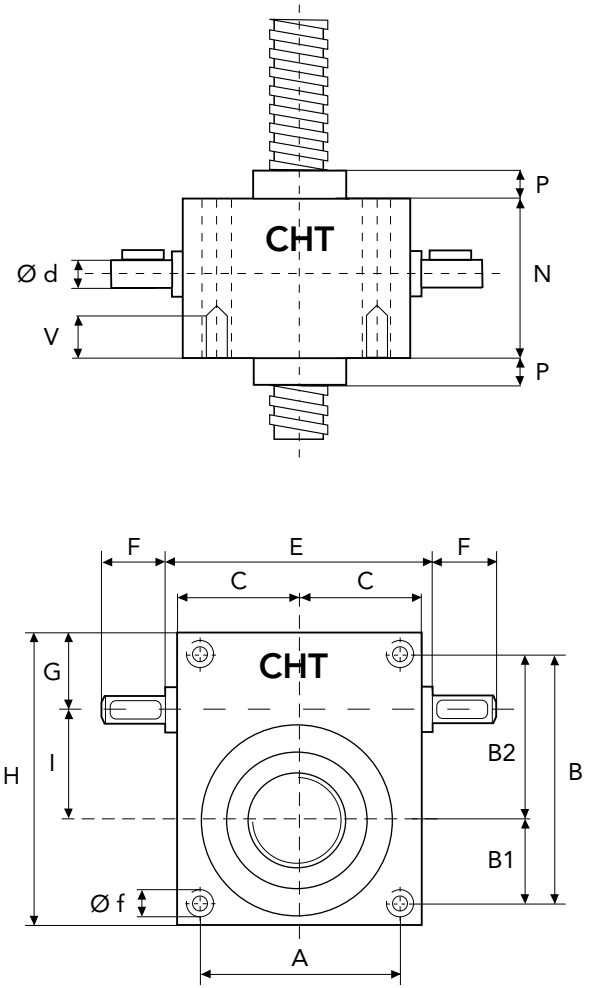

	A	B	B1	B2	C	E	F	G	H
CHS6	134	175	60	115	87,5	-	47,5	68	216
	I	N	P	P1	V	$\varnothing d$	$\varnothing f$	$\varnothing s$	TPN
CHS6	70	150	40	25	40	25	M20	90	60x9

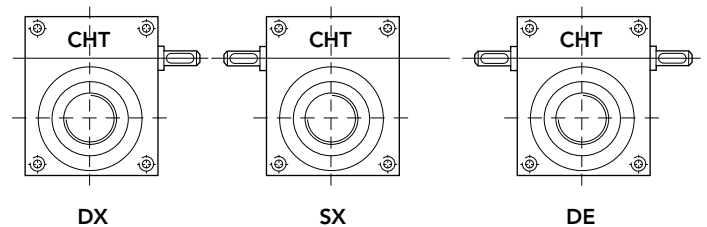



# SERIES CHS 6 RS

# ROTATING SCREW

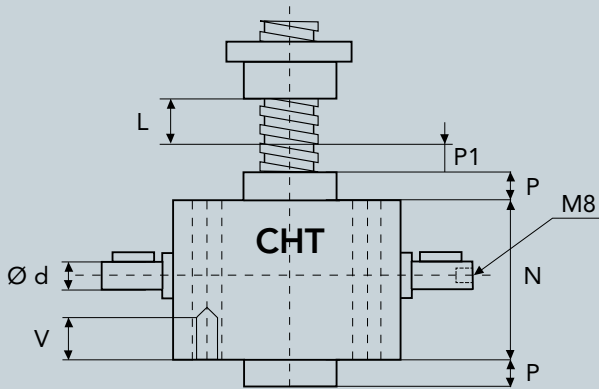

L = CORSA

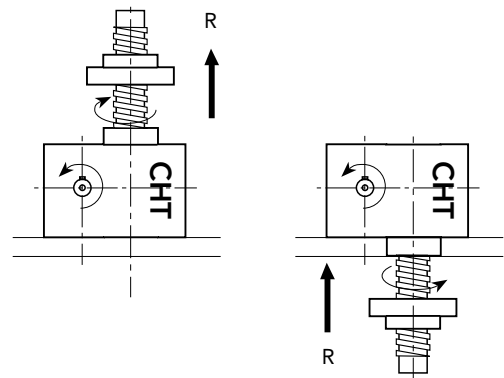
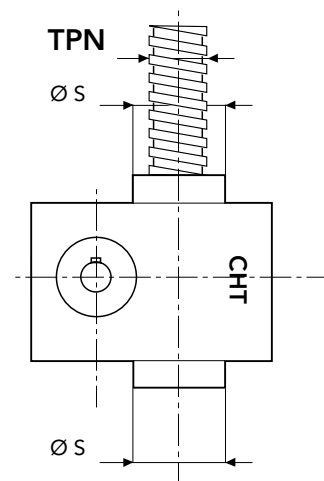
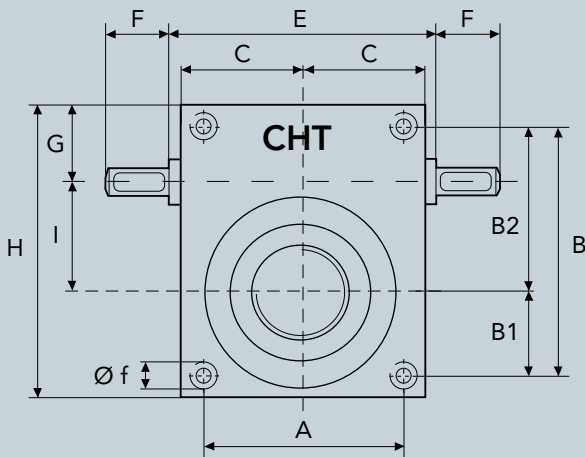

SERIES CHS 6 TS - 15000 daN · TPN 60x9

## BRONZE NUT

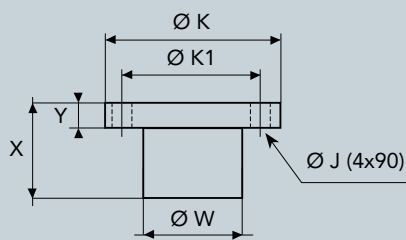

## MOTORS ADAPTORS FLANGES

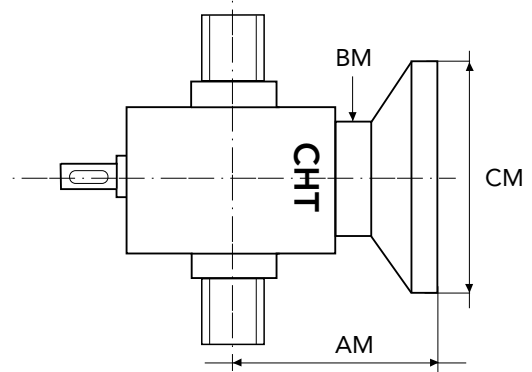

	X	Y	Ø W	Ø K	Ø K1	Ø J
CHS6	120	25	80	110	92	10,5

MOTOR	FLANGE TYPE	CM	AM	BM
GR. 80	B5	200	140	108
	B14	120		
GR. 90	B5	200	140	108
	B14	140		
GR. 100/112	B5	250	140	108
	B14	160		

## CONFIGURATION

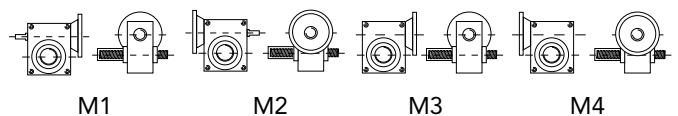



# SCREW JACK PERFORMANCE CHS 6

## SCREW-JACKS WITH BALL SCREWS FOR TRANSLATING SCREW BY INTEGRATED NUT

Consult our technical DPT

SCREW JACK PERFORMANCE SERIES CHS 6

load daN			15000		7500		5000		2000	
ratio	lifting speed mm	input speed	Pn Kw	Mt daNm	Pn Kw	Mt daNm	Pn Kw	Mt daNm	Pn Kw	Mt daNm
5	2700	1500	35,17	22,39	17,59	11,20	11,72	7,46	4,69	2,99
	1800	1000	23,45	22,39	11,72	11,20	7,82	7,46	3,13	2,99
	1350	750	17,59	22,39	8,79	11,20	5,86	7,46	2,34	2,99
	90	50	1,17	22,39	0,59	11,20	0,39	7,46	0,16	2,99

load daN			15000		7500		5000		2000	
ratio	lifting speed mm	input speed	Pn Kw	Mt daNm	Pn Kw	Mt daNm	Pn Kw	Mt daNm	Pn Kw	Mt daNm
10	1350	1500	18,76	11,94	9,38	5,97	6,25	3,98	2,50	1,59
	900	1000	12,51	11,94	6,25	5,97	4,17	3,98	1,67	1,59
	675	750	9,38	11,94	4,69	5,97	3,13	3,98	1,25	1,59
	45	50	0,63	11,94	0,31	5,97	0,21	3,98	0,07	1,59

load daN			15000		7500		5000		2000	
ratio	lifting speed mm	input speed	Pn Kw	Mt daNm	Pn Kw	Mt daNm	Pn Kw	Mt daNm	Pn Kw	Mt daNm
30	450	1500	6,70	4,27	3,35	2,13	2,23	1,42	0,89	0,57
	300	1000	4,47	4,27	2,23	2,13	1,49	1,42	0,60	0,57
	225	750	3,35	4,27	1,67	2,13	1,12	1,42	0,45	0,57
	15	50	0,22	4,27	0,11	2,13	0,07	1,42	0,07	0,57



# CHS 6

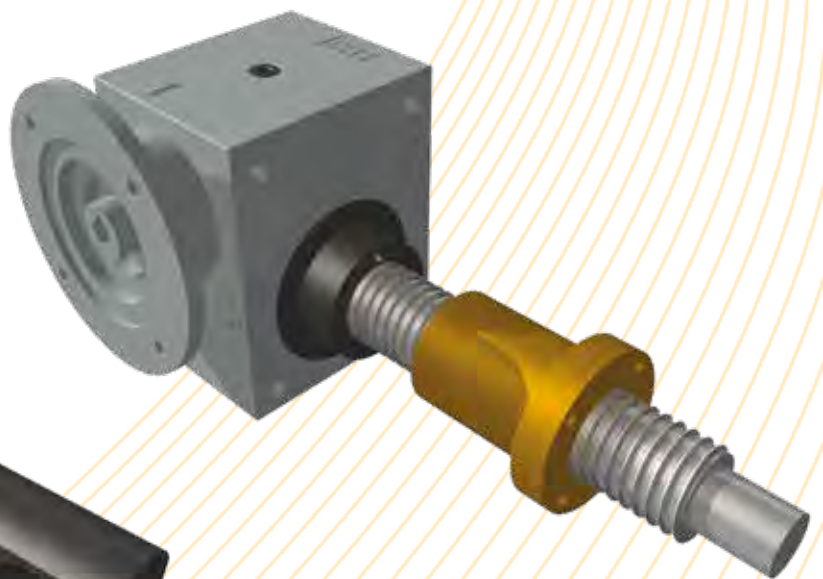
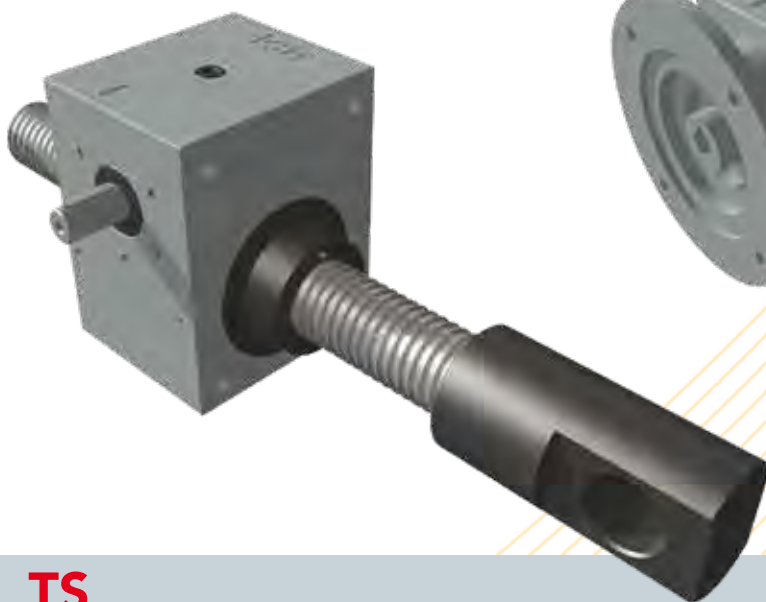
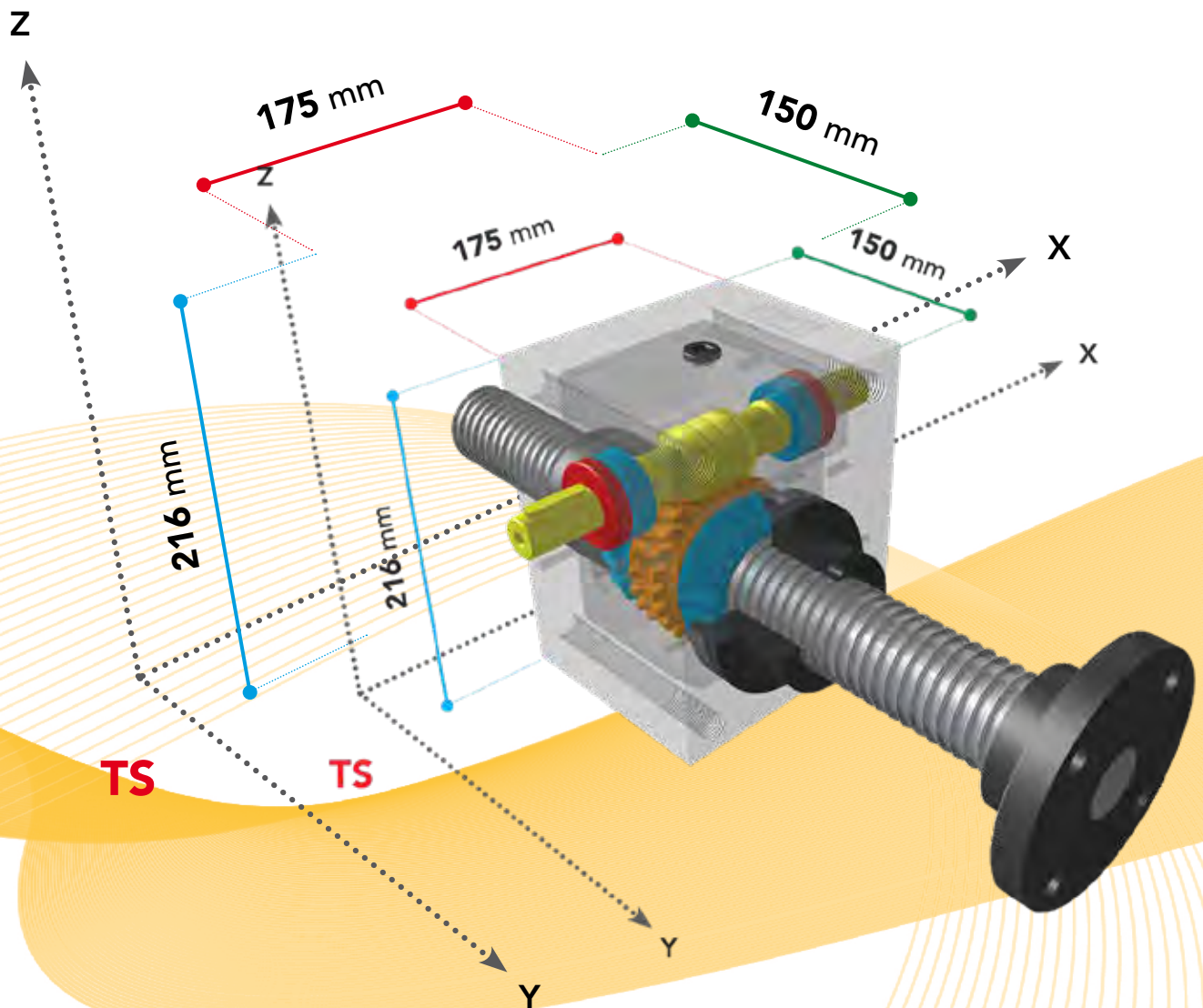

**TS**

**RS**



SCREW JACK MODEL		CHS 7
LOAD	daN (Kg)	20000
TPN SCREW	DIAMETER mm PITCH mm	70 10
GEAR RATIOS	FAST SPEED NORMAL SPEED SLOW SPEED	5:1 10:1 30:1
STROKE FOR INPUT REV.	FAST SPEED NORMAL SPEED SLOW SPEED	2 1 0,33
EFFICIENCY	FAST SPEED NORMAL SPEED SLOW SPEED	18,5% 17,5% 16%
JACK WEIGHT (Kg)		54
SCREW WEIGHT TPN X 100 mm (Kg)		2,8
CASE MATERIAL		GJS 450
GREASE QTY (Kg)		1,5
GREASE TYPE	AGIP GR MU EP2	
OPERATING TEMPERATURE	-5° C +80° C	

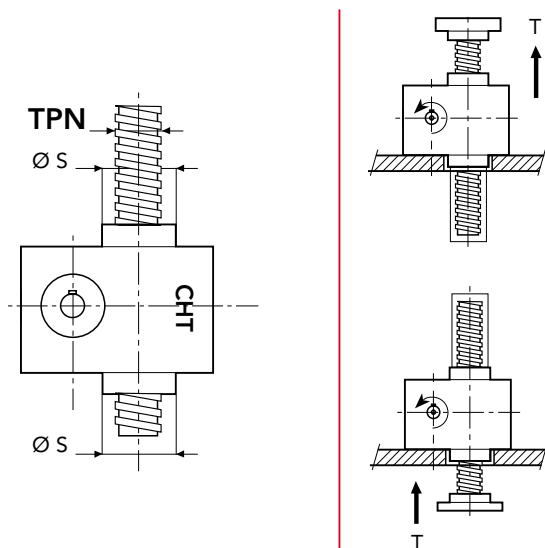
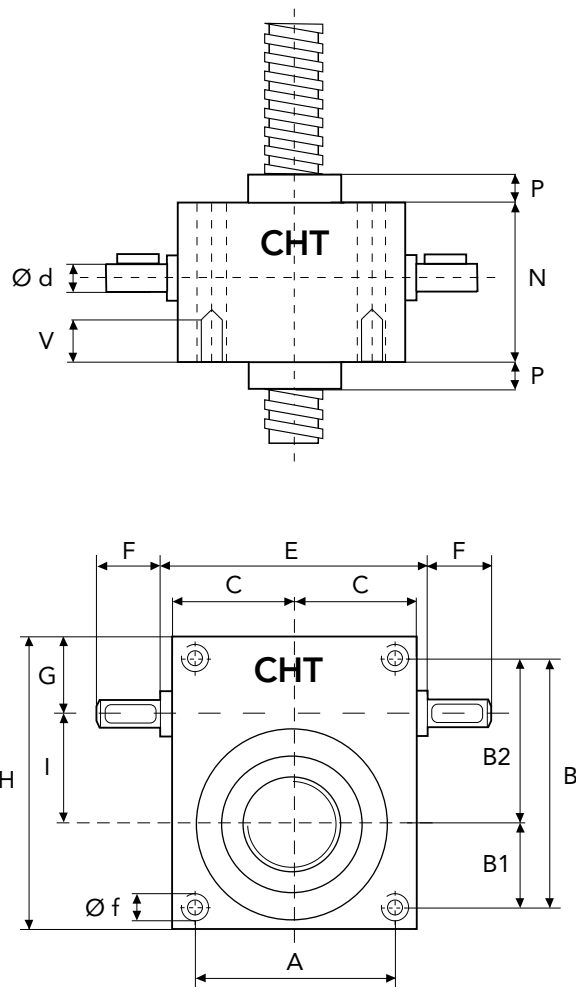

	A	B	B1	B2	C	E	F	G	H
CHS7	180	230	90	140	116	-	60	76	282
	I	N	P	P1	V	Ø d	Ø f	Ø s	TPN
CHS7	90	176	40	30	45	30	M30	120	70x10

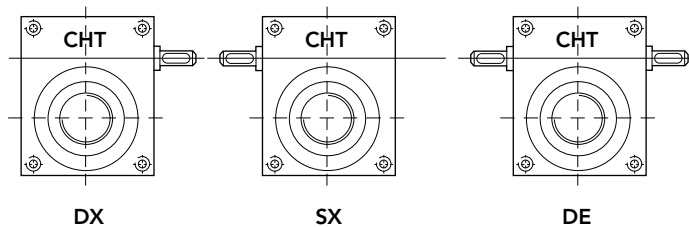



# SERIES CHS 7 RS

# ROTATING SCREW

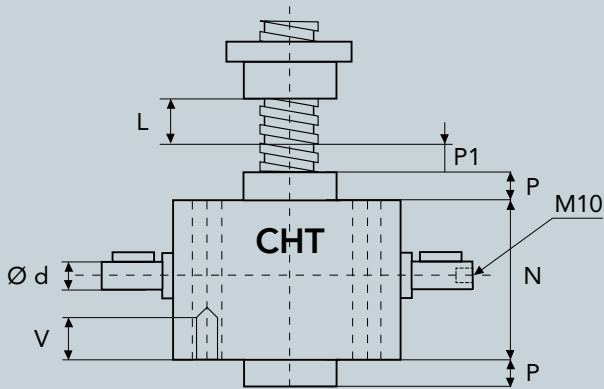

L = CORSA

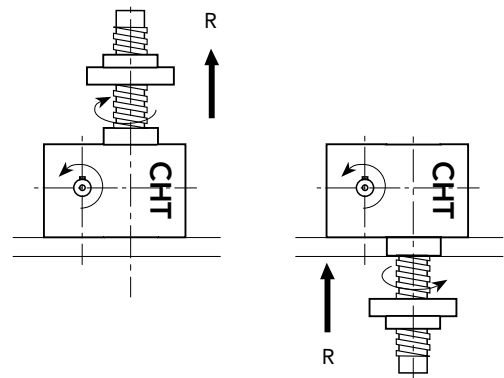
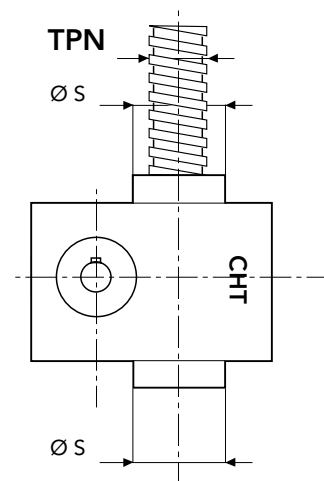
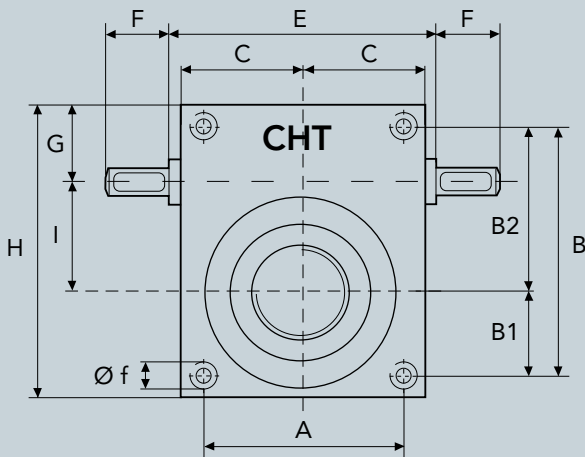

SERIES CHS 7 TS - 20000 daN · TPN 70x10

## BRONZE NUT

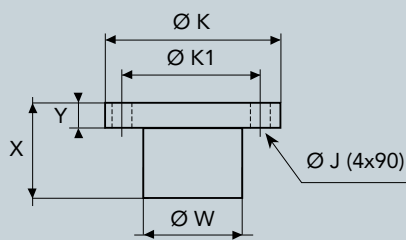

## MOTORS ADAPTORS FLANGES

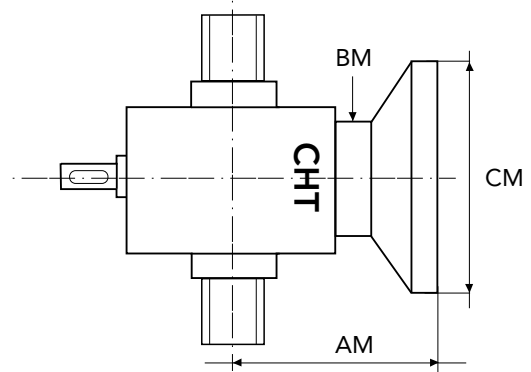

	X	Y	Ø W	Ø K	Ø K1	Ø J
CHS7	105	30	100	180	140	18

MOTOR	FLANGE TYPE	CM	AM	BM
GR. 90	B5	200		
GR. 100/112	B5	250	200	130
	B14	160		
GR. 132	B5	300		
	B14	200		

## CONFIGURATION

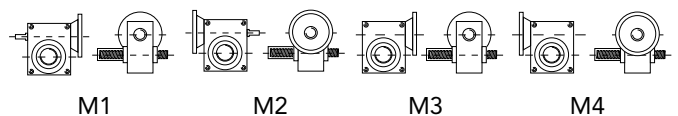



# SCREW JACK PERFORMANCE CHS 7

## SCREW-JACKS WITH BALL SCREWS FOR TRANSLATING SCREW BY INTEGRATED NUT

Consult our technical DPT

SCREW JACK PERFORMANCE SERIES CHS 7

load daN			20000		15000		7500		2500	
ratio	lifting speed mm	input speed	Pn Kw	Mt daNm	Pn Kw	Mt daNm	Pn Kw	Mt daNm	Pn Kw	Mt daNm
5	3000	1500	52,65	33,52	39,49	25,14	19,75	12,57	6,58	4,19
	2000	1000	35,10	33,52	26,33	25,14	13,16	12,57	4,39	4,19
	1500	750	26,33	33,52	19,75	25,14	9,87	12,57	3,29	4,19
	100	50	1,76	33,52	1,32	25,14	0,66	12,57	0,22	4,19

load daN			20000		15000		7500		2500	
ratio	lifting speed mm	input speed	Pn Kw	Mt daNm	Pn Kw	Mt daNm	Pn Kw	Mt daNm	Pn Kw	Mt daNm
10	1500	1500	27,95	17,79	20,96	13,34	10,48	6,67	3,49	2,22
	1000	1000	18,63	17,79	13,97	13,34	6,99	6,67	2,33	2,22
	750	750	13,97	17,79	10,48	13,34	5,24	6,67	1,75	2,22
	50	50	0,93	17,79	0,70	13,34	0,35	6,67	0,07	2,22

load daN			20000		15000		7500		2500	
ratio	lifting speed mm	input speed	Pn Kw	Mt daNm	Pn Kw	Mt daNm	Pn Kw	Mt daNm	Pn Kw	Mt daNm
30	500	1500	9,98	6,36	7,49	4,77	3,74	2,38	1,25	0,79
	333	1000	6,66	6,36	4,99	4,77	2,50	2,38	0,83	0,79
	250	750	4,99	6,36	3,74	4,77	1,87	2,38	0,62	0,79
	17	50	0,33	6,36	0,25	4,77	0,07	2,38	0,07	0,79



# CHS 7

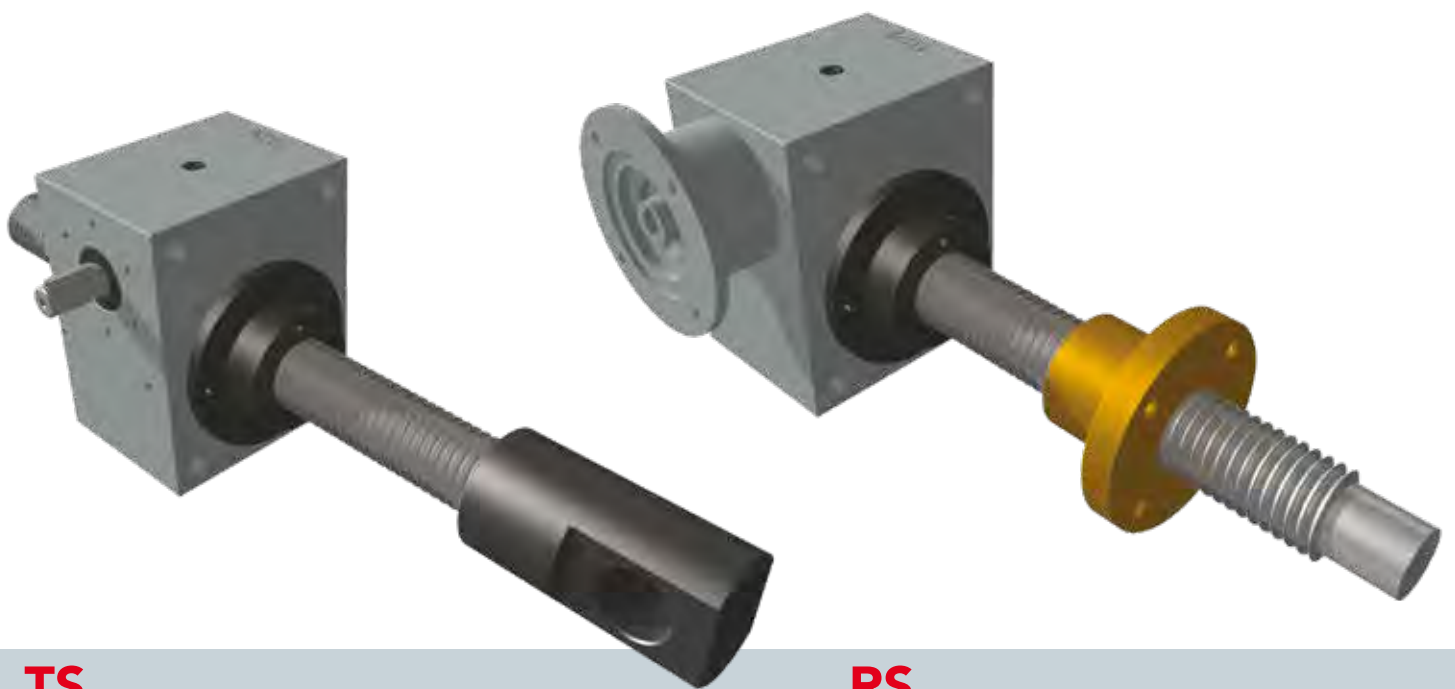
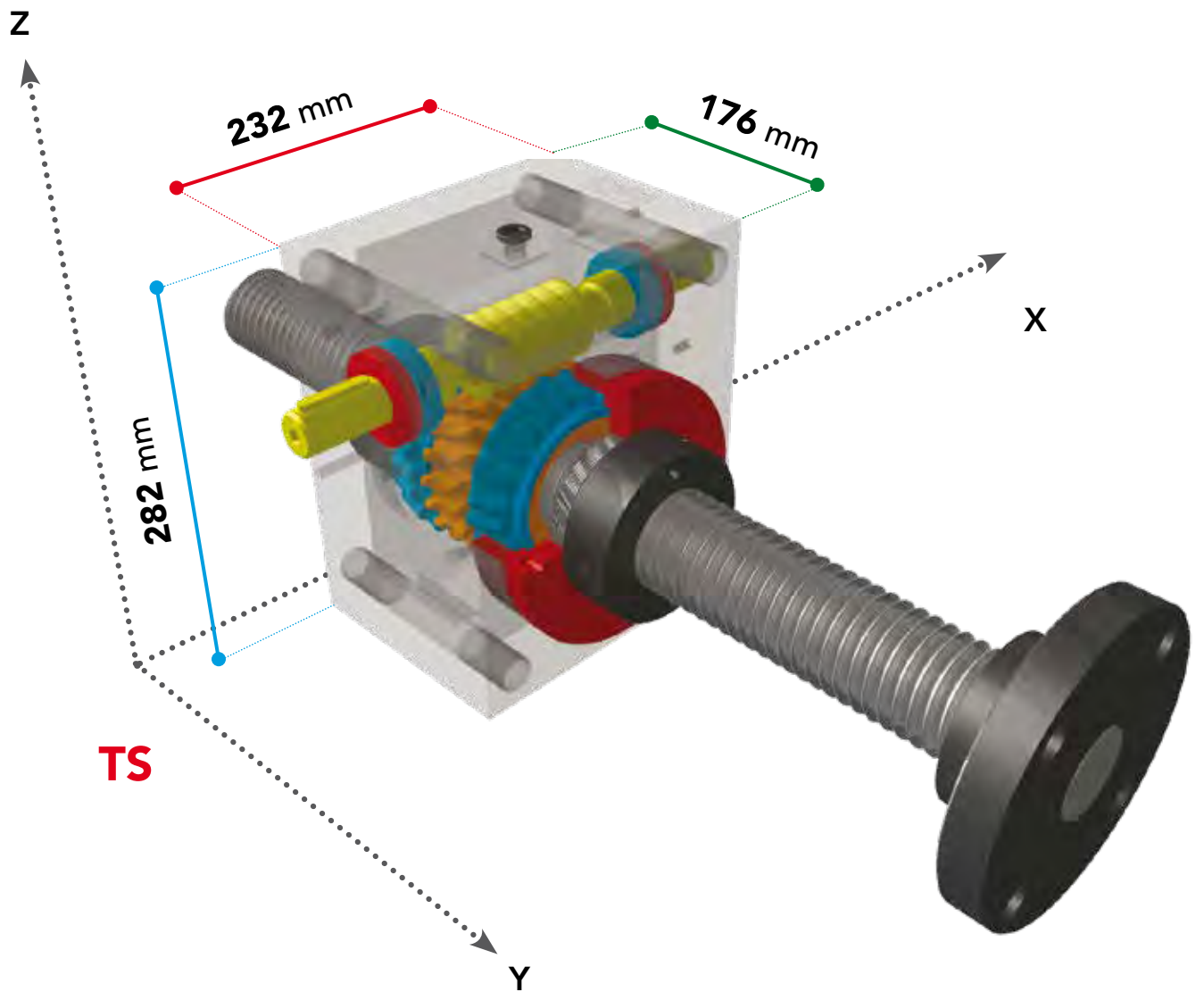



# SERIES CHS 8 TS

# TRANSLATING SCREW

SERIES CHS 8 TS - 25000 daN · TPN 80x10

SCREW JACK MODEL		CHS 8
LOAD	daN (Kg)	25000
TPN SCREW	DIAMETER mm	80
	PITCH mm	10
GEAR RATIOS	FAST SPEED	5:1
	NORMAL SPEED	10:1
	SLOW SPEED	30:1
STROKE FOR INPUT REV.	FAST SPEED	2
	NORMAL SPEED	1
	SLOW SPEED	0,33
EFFICIENCY	FAST SPEED	18,5%
	NORMAL SPEED	17,5%
	SLOW SPEED	16%
JACK WEIGHT (Kg)		54
SCREW WEIGHT TPN X 100 mm (Kg)		3,2
CASE MATERIAL		GJS 450
GREASE QTY (Kg)		1,5
GREASE TYPE	AGIP GR MU EP2	
OPERATING TEMPERATURE	-5° C +80° C	

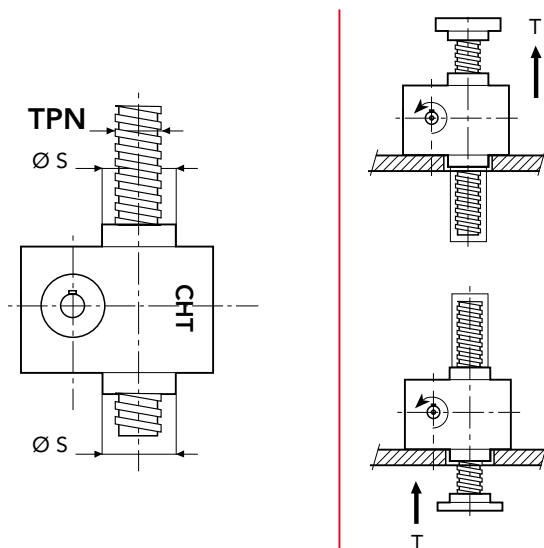
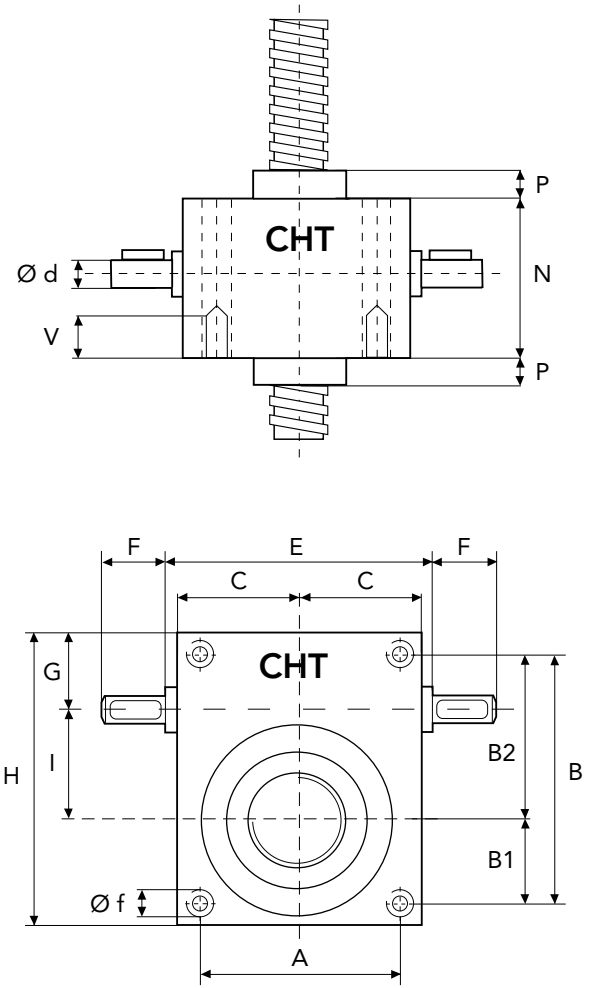

	A	B	B1	B2	C	E	F	G	H
CHS8	180	230	90	140	116	-	60	76	282
	I	N	P	P1	V	$\varnothing d$	$\varnothing f$	$\varnothing s$	TPN
CHS8	90	176	40	30	45	30	M30	120	80x10

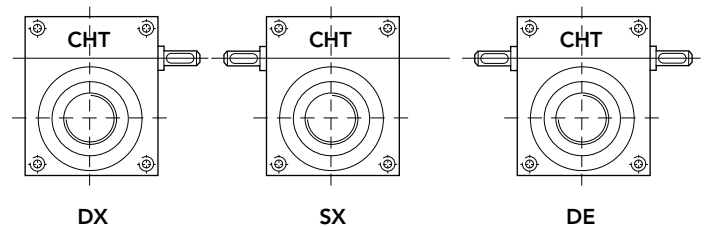



# SERIES CHS 8 RS

# ROTATING SCREW

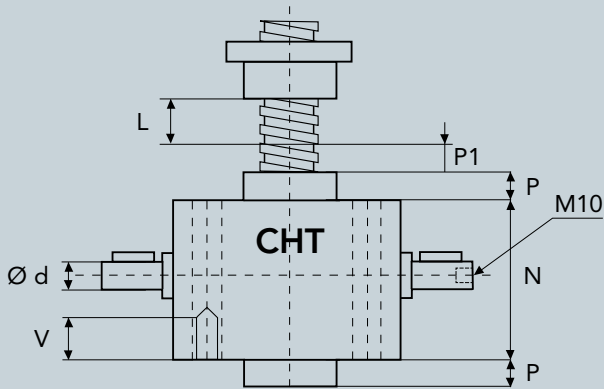

L = CORSA

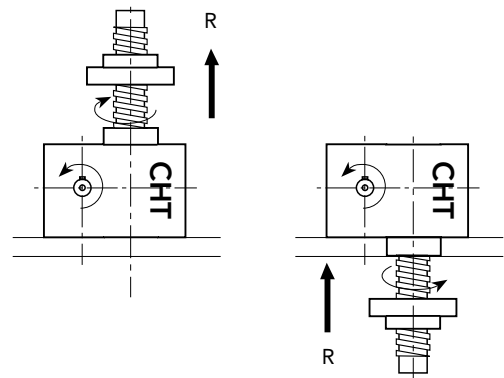
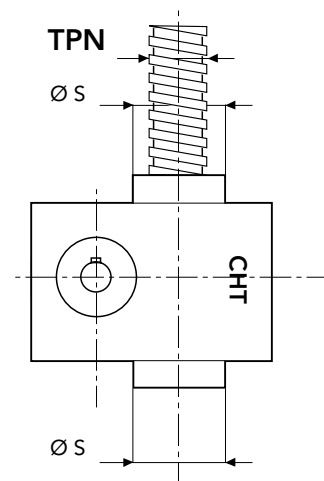
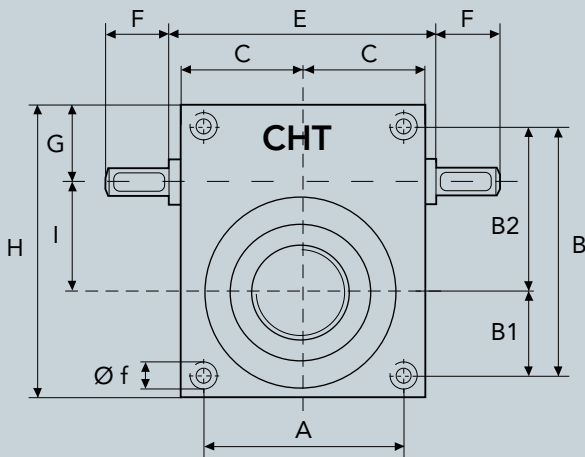

SERIES CHS 8 TS - 25000 daN · TPN 80x10

## BRONZE NUT

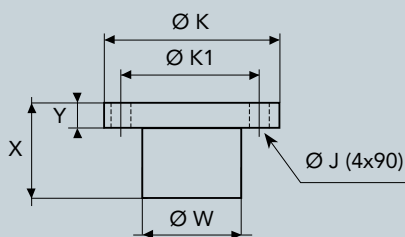

	X	Y	Ø W	Ø K	Ø K1	Ø J
CHS8	110	30	110	190	150	18

## MOTORS ADAPTORS FLANGES

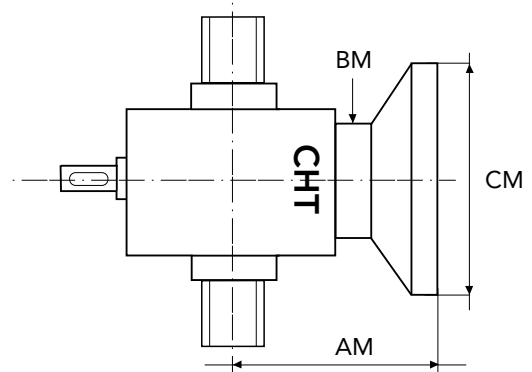

MOTOR	FLANGE TYPE	CM	AM	BM
GR. 90	B5	200		
GR. 100/112	B5	250	200	130
	B14	160		
GR. 132	B5	300		
	B14	200		

## CONFIGURATION

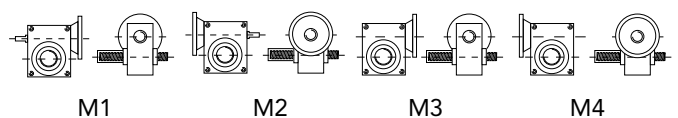



# SCREW JACK PERFORMANCE CHS 8

## SCREW-JACKS WITH BALL SCREWS FOR TRANSLATING SCREW BY INTEGRATED NUT

Consult our technical DPT

SCREW JACK PERFORMANCE SERIES CHS 8

load daN			25000		20000		10000		3000	
ratio	lifting speed mm	input speed	Pn Kw	Mt daNm	Pn Kw	Mt daNm	Pn Kw	Mt daNm	Pn Kw	Mt daNm
5	3000	1500	67,60	43,04	54,08	34,43	27,04	17,21	8,11	5,16
	2000	1000	45,06	43,04	36,05	34,43	18,03	17,21	5,41	5,16
	1500	750	33,80	43,04	27,04	34,43	13,52	17,21	4,06	5,16
	100	50	2,25	43,04	1,80	34,43	0,90	17,21	0,27	5,16

load daN			25000		20000		10000		3000	
ratio	lifting speed mm	input speed	Pn Kw	Mt daNm	Pn Kw	Mt daNm	Pn Kw	Mt daNm	Pn Kw	Mt daNm
10	1500	1500	35,73	22,75	28,58	18,20	14,29	9,10	4,29	2,73
	1000	1000	23,82	22,75	19,06	18,20	9,53	9,10	2,86	2,73
	750	750	17,86	22,75	14,29	18,20	7,15	9,10	2,14	2,73
	50	50	1,19	22,75	0,95	18,20	0,48	9,10	0,07	2,73

load daN			25000		20000		10000		3000	
ratio	lifting speed mm	input speed	Pn Kw	Mt daNm	Pn Kw	Mt daNm	Pn Kw	Mt daNm	Pn Kw	Mt daNm
30	500	1500	12,63	8,04	10,11	6,43	5,05	3,22	1,52	0,97
	333	1000	8,42	8,04	6,74	6,43	3,37	3,22	1,01	0,97
	250	750	6,32	8,04	5,05	6,43	2,53	3,22	0,76	0,97
	17	50	0,42	8,04	0,34	6,43	0,07	3,22	0,07	0,97



# CHS 8

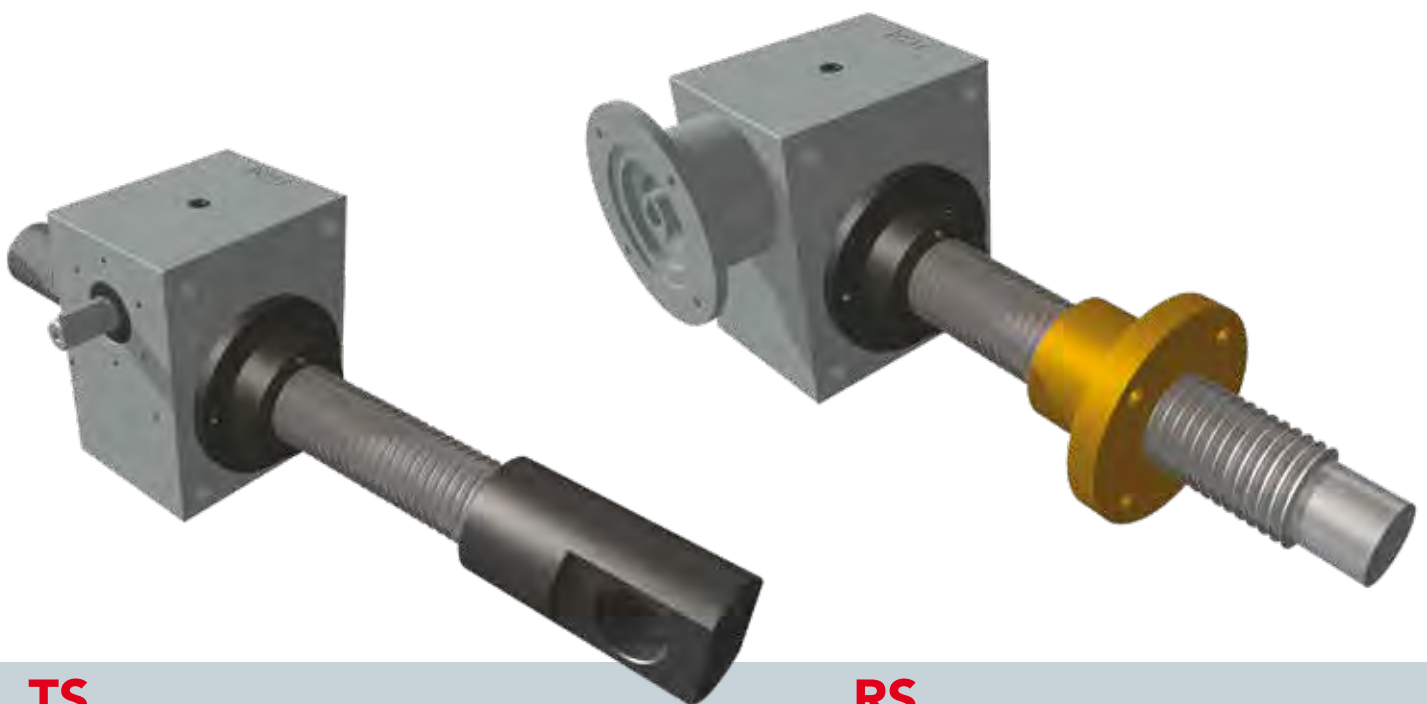
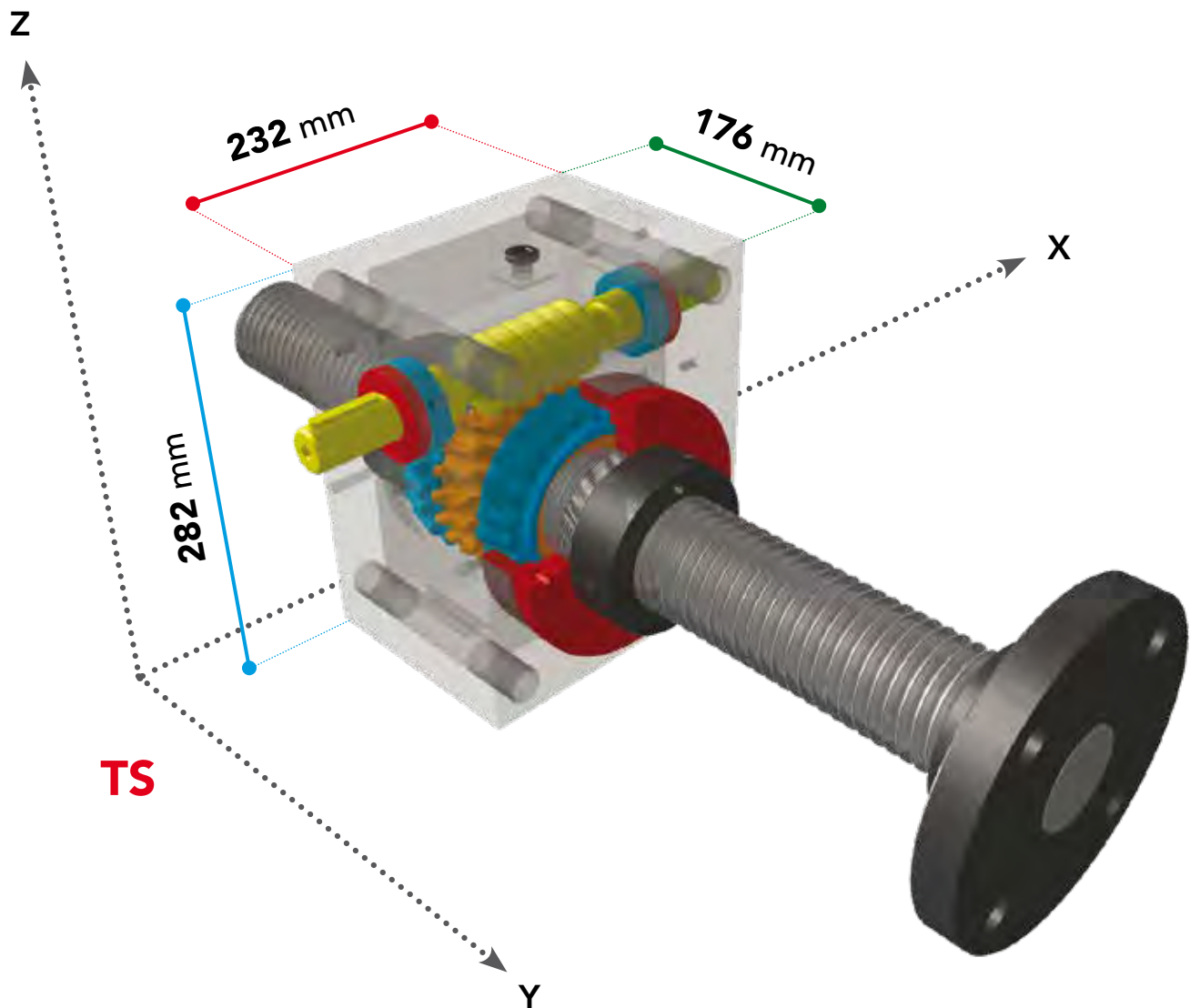



# SERIES CHS 9 TS

# TRANSLATING SCREW

## HEAVY LINE

SERIES CHS 9 TS - 30000 daN · TPN 90x10

SCREW JACK MODEL		CHS 9
LOAD	daN (Kg)	30000
TPN SCREW	DIAMETER mm PITCH mm	90 10
GEAR RATIOS	NORMAL SPEED SLOW SPEED	10:1 30:1
STROKE FOR INPUT REV.	NORMAL SPEED SLOW SPEED	1 0,33
EFFICIENCY	NORMAL SPEED SLOW SPEED	18,0% 12,5%
JACK WEIGHT (Kg)		110
SCREW WEIGHT TPN X 100 mm (Kg)		4,6
CASE MATERIAL		Fe 510
GREASE QTY (Kg)		2,3
GREASE TYPE	AGIP GR MU EP2	
OPERATING TEMPERATURE	-5° C +80° C	

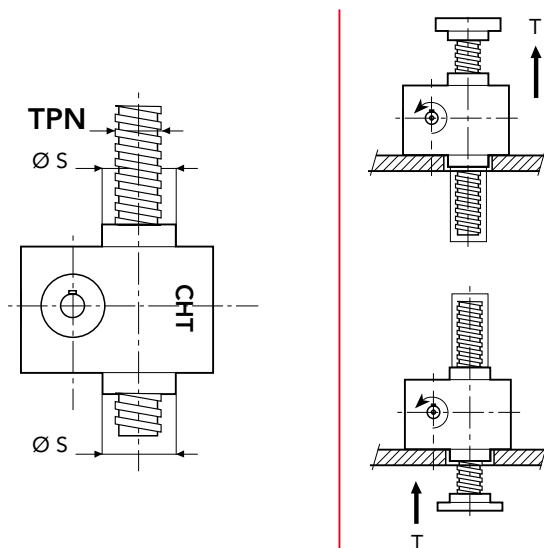
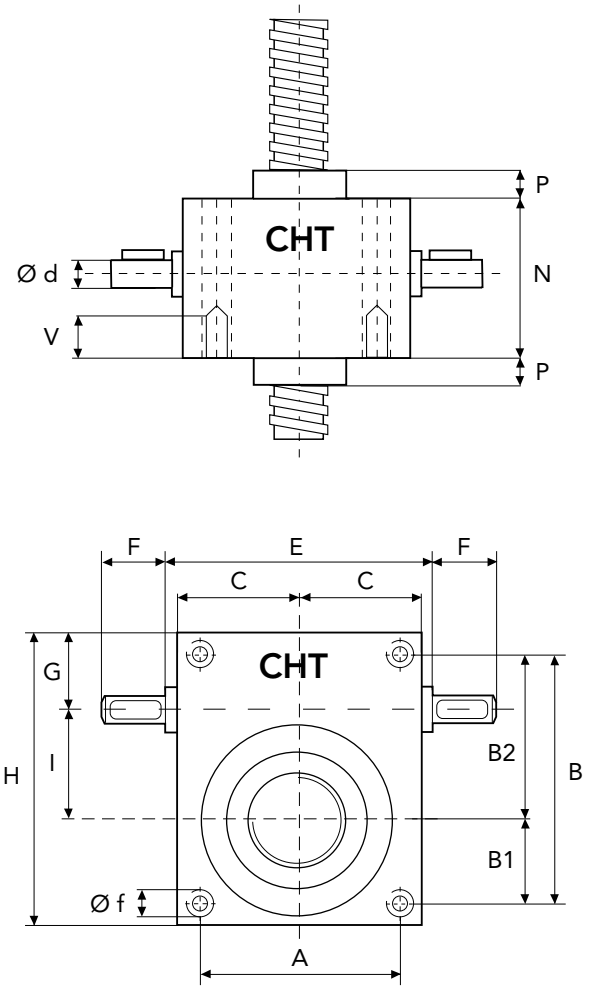

	A	B	B1	B2	C	E	F	G	H
CHS9	200	270	100	170	125	-	70	85	320
	I	N	P	P1	V	Ø d	Ø f	Ø s	TPN
CHS9	110	230	50	40	40	40	M30	150	90x10

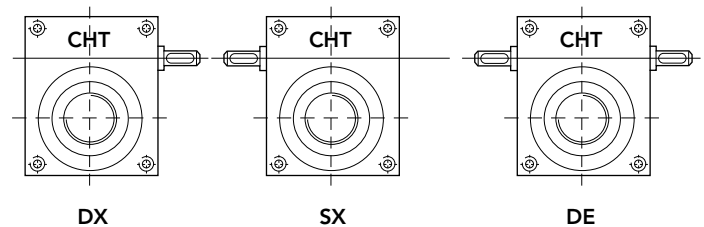



# SERIES CHS 9 RS

# ROTATING SCREW

## HEAVY LINE

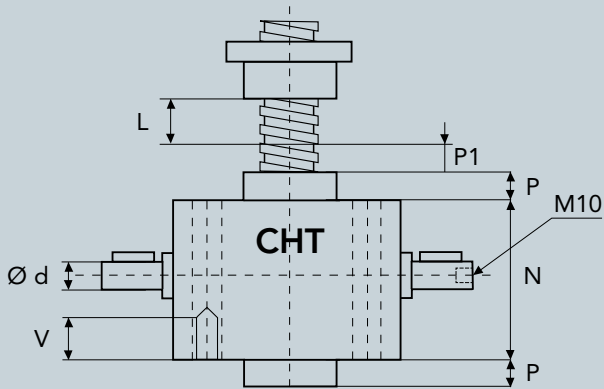

L = CORSA

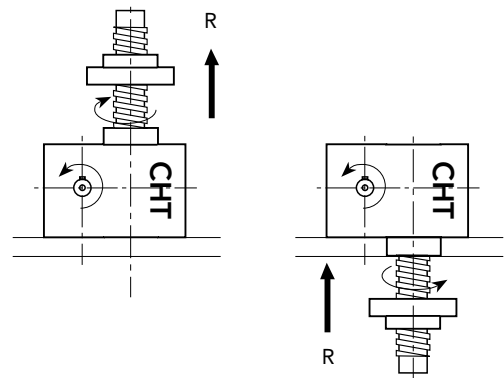
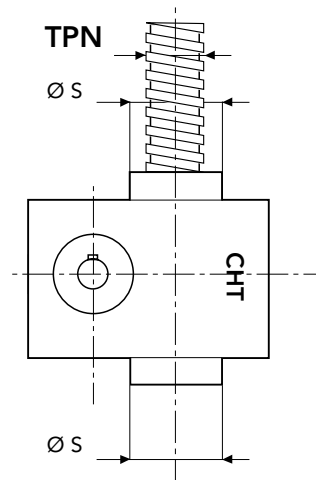
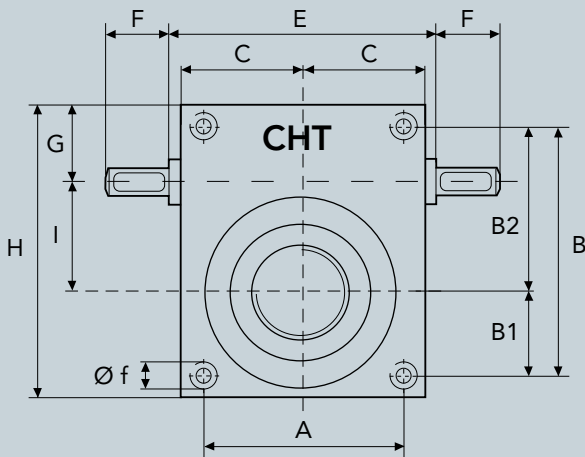

SERIES CHS 9 TS - 30000 daN · TPN 90x10

### BRONZE NUT

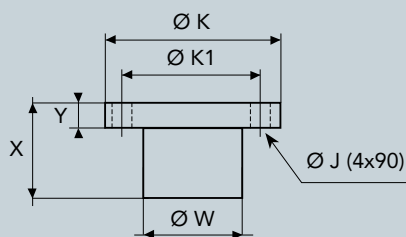

### MOTORS ADAPTORS FLANGES

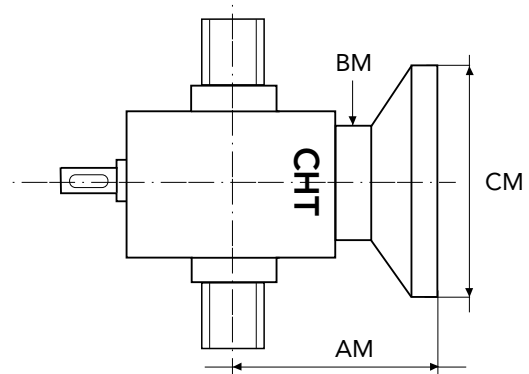

**FOR SPECIAL EXECUTION**  
please consult our technical DPT

	X	Y	Ø W	Ø K	Ø K1	Ø J
CHS9	135	45	150	230	190	20

### CONFIGURATION

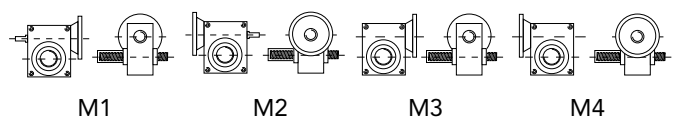



## SCREW-JACKS WITH BALL SCREWS FOR TRANSLATING SCREW BY INTEGRATED NUT

Consult our technical DPT

SCREW JACK PERFORMANCE SERIES CHS 9

load daN			30000		20000		10000		5000	
ratio	lifting speed mm	input speed	Pn Kw	Mt daNm	Pn Kw	Mt daNm	Pn Kw	Mt daNm	Pn Kw	Mt daNm
10	1500	1500	41,68	26,54	27,79	17,69	13,89	8,85	6,95	4,42
	1000	1000	27,79	26,54	18,53	17,69	9,26	8,85	4,63	4,42
	750	750	20,84	26,54	13,89	17,69	6,95	8,85	3,47	4,42
	50	50	1,39	26,54	0,93	17,69	0,46	8,85	0,07	4,42

load daN			30000		20000		10000		3000	
ratio	lifting speed mm	input speed	Pn Kw	Mt daNm	Pn Kw	Mt daNm	Pn Kw	Mt daNm	Pn Kw	Mt daNm
30	500	1500	20,01	12,74	13,34	8,49	6,67	4,25	3,33	2,12
	333	1000	13,34	12,74	8,89	8,49	4,45	4,25	2,22	2,12
	250	750	10,00	12,74	6,67	8,49	3,33	4,25	1,67	2,12
	17	50	0,67	12,74	0,44	8,49	0,07	4,25	0,07	2,12

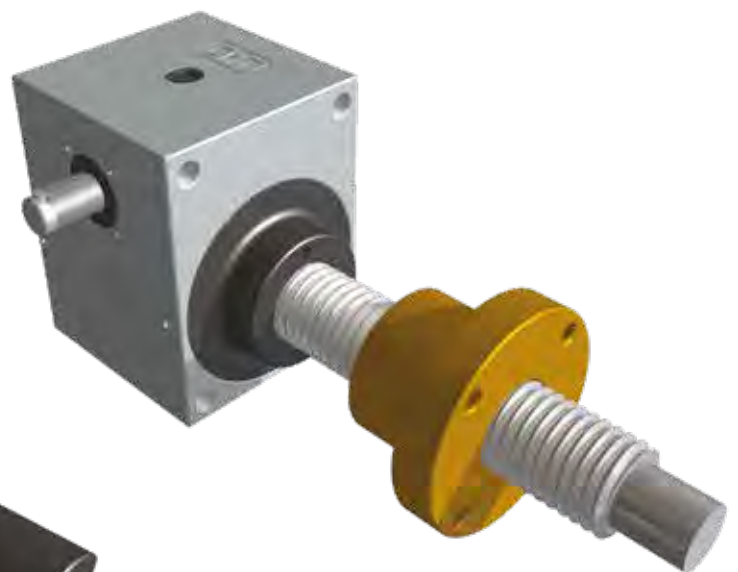
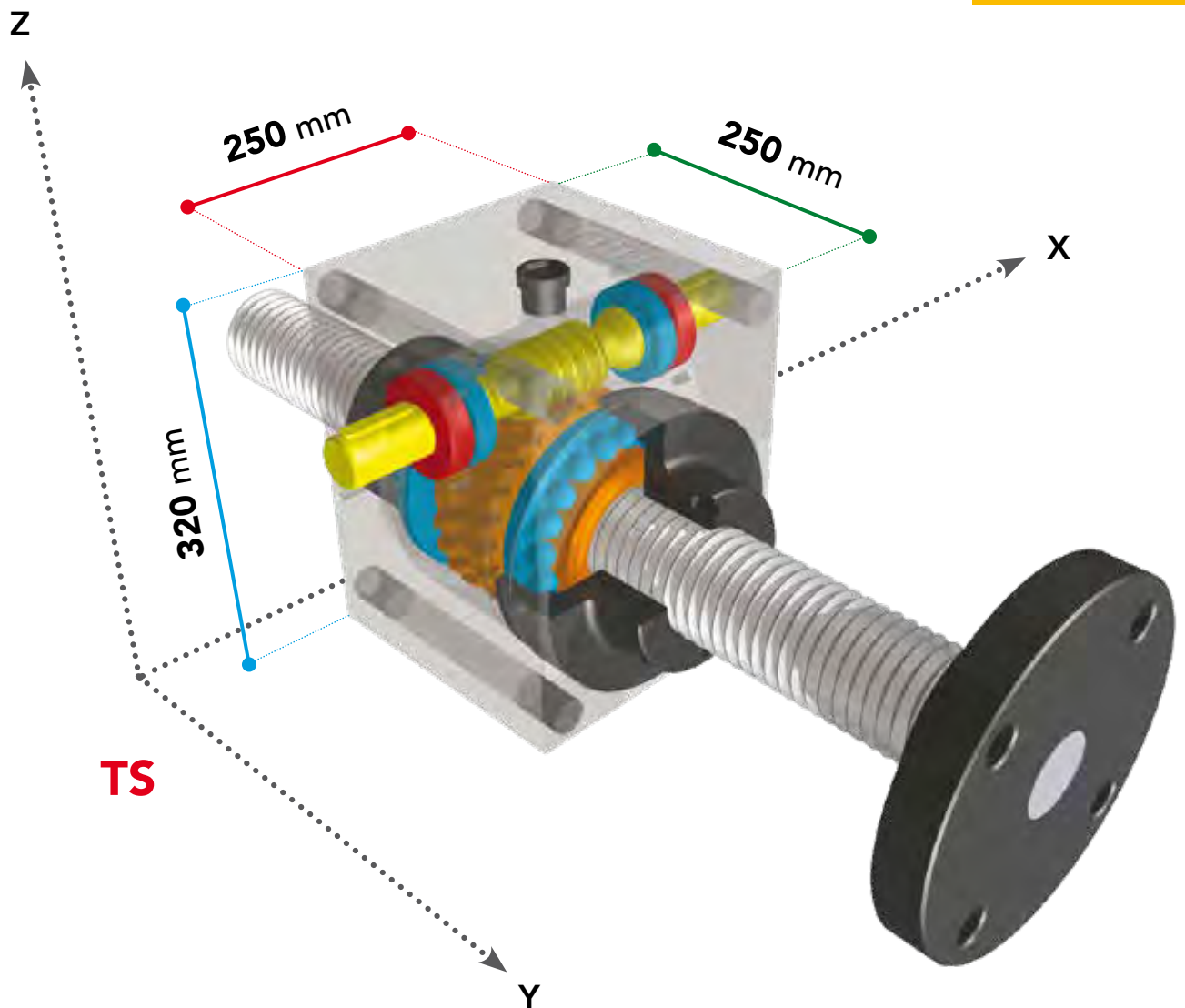

TS

RS



# SERIES CHS 10 TS

# TRANSLATING SCREW

## HEAVY LINE

SERIES CHS 10 TS - 40000 daN · TPN 100x12

SCREW JACK MODEL		CHS 10
LOAD	daN (Kg)	40000
TPN SCREW	DIAMETER mm PITCH mm	100 12
GEAR RATIOS	NORMAL SPEED SLOW SPEED	10:1 30:1
STROKE FOR INPUT REV.	NORMAL SPEED SLOW SPEED	1,2 0,4
EFFICIENCY	NORMAL SPEED SLOW SPEED	18,0% 12,5%
JACK WEIGHT (Kg)		250
SCREW WEIGHT TPN X 100 mm (Kg)		5,6
CASE MATERIAL		Fe 510
GREASE QTY (Kg)		4
GREASE TYPE	AGIP GR MU EP2	
OPERATING TEMPERATURE	-5° C +80° C	

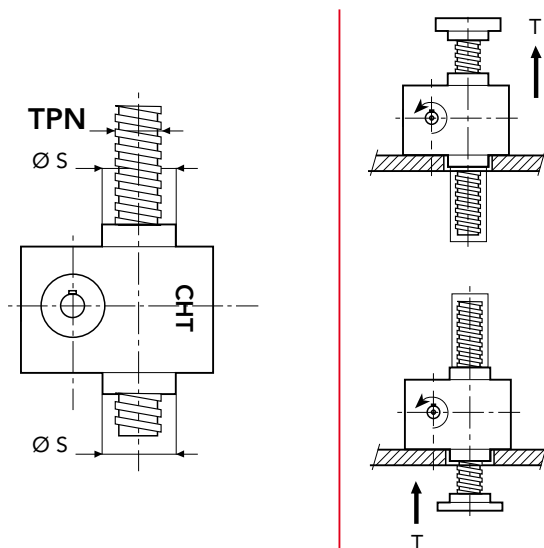
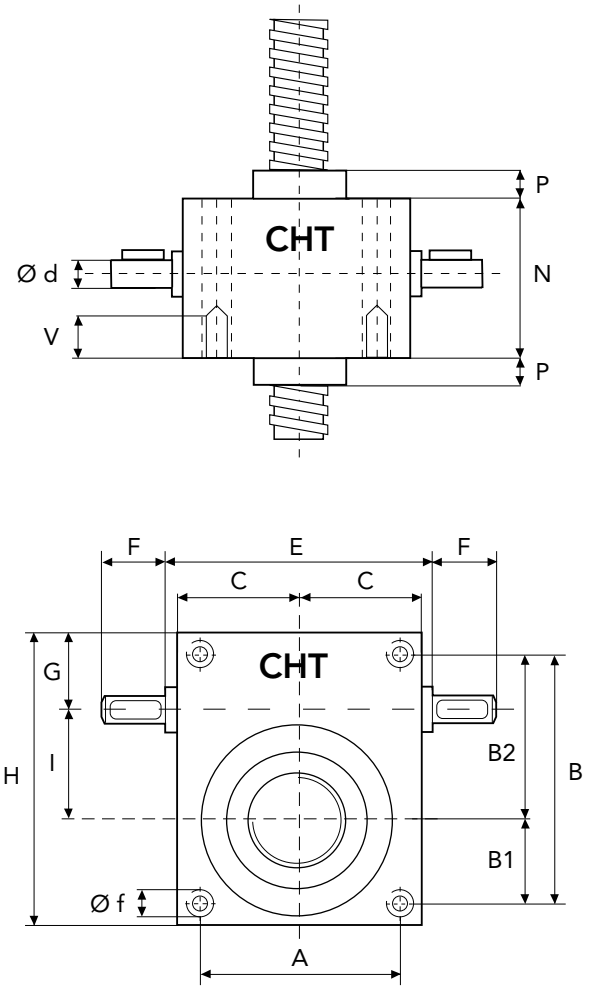

	A	B	B1	B2	C	E	F	G	H
CHS10	230	355	135	220	160	-	85	105	405
	I	N	P	P1	V	Ø d	Ø f	Ø s	TPN
CHS10	140	270	50	40	45	55	M30	210	100x12

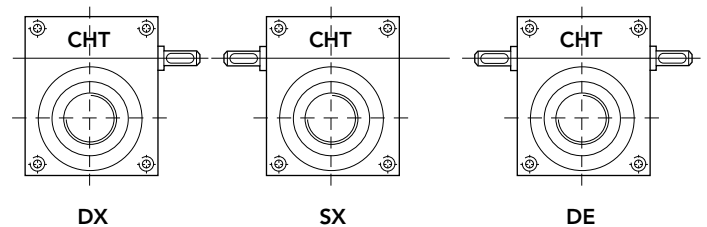



# SERIES CHS 10 RS

# ROTATING SCREW

## HEAVY LINE

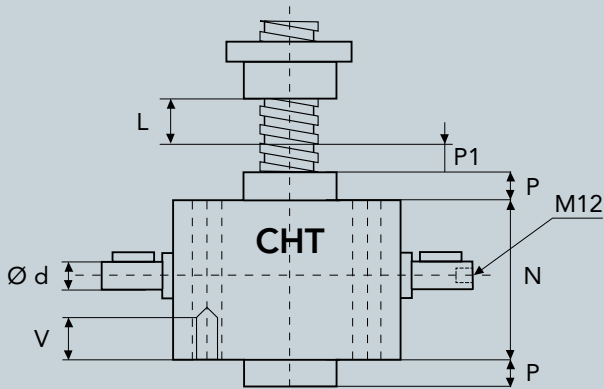

L = CORSA

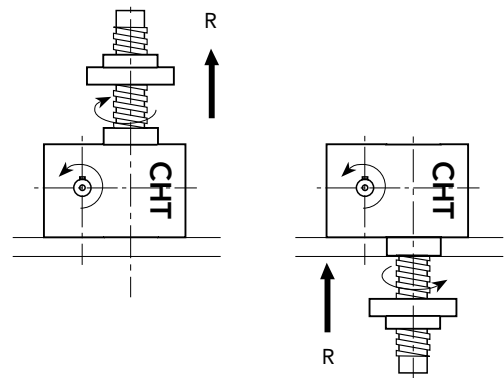
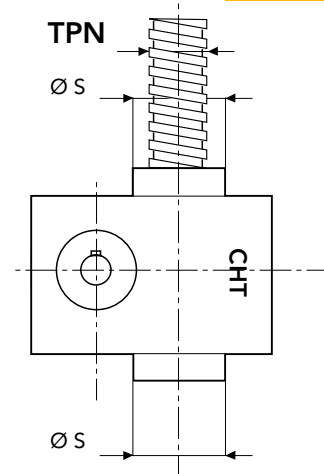
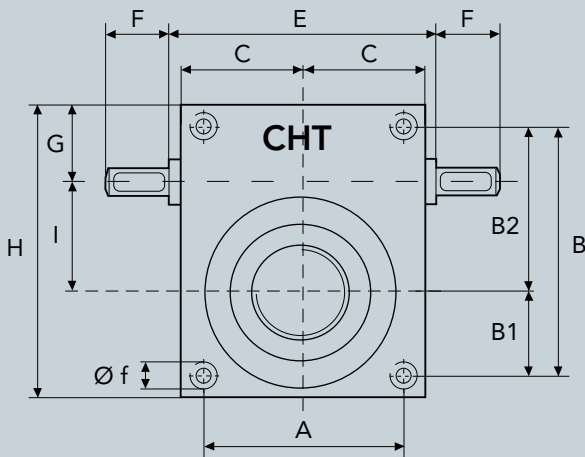

SERIES CHS 10 TS - 40000 daN · TPN 100x12

### BRONZE NUT

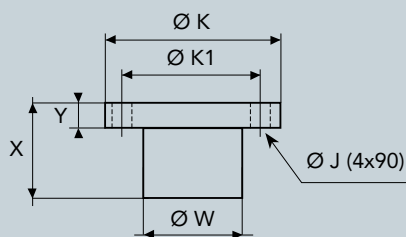

### MOTORS ADAPTORS FLANGES

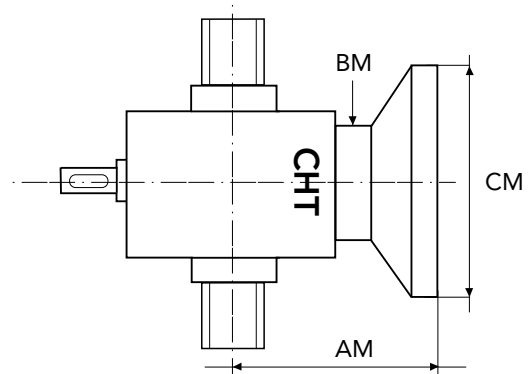

**FOR SPECIAL EXECUTION**  
please consult our technical DPT

	X	Y	Ø W	Ø K	Ø K1	Ø J
CHS10	135	45	150	230	190	20

### CONFIGURATION

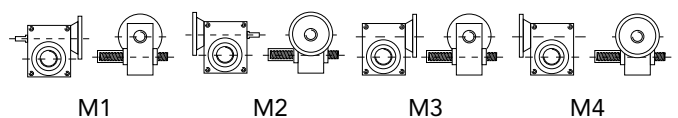



## SCREW-JACKS WITH BALL SCREWS FOR TRANSLATING SCREW BY INTEGRATED NUT

Consult our technical DPT

SCREW JACK PERFORMANCE SERIES CHS 10

load daN			40000		30000		15000		5000	
ratio	lifting speed mm	input speed	Pn Kw	Mt daNm	Pn Kw	Mt daNm	Pn Kw	Mt daNm	Pn Kw	Mt daNm
10	1800	1500	66,70	42,46	50,02	31,85	25,01	15,92	8,34	5,31
	1200	1000	44,46	42,46	33,35	31,85	16,67	15,92	5,56	5,31
	900	750	33,35	42,46	25,01	31,85	12,51	15,92	4,17	5,31
	60	50	2,22	42,46	1,67	31,85	0,83	15,92	1,07	5,31

load daN			40000		30000		15000		5000	
ratio	lifting speed mm	input speed	Pn Kw	Mt daNm	Pn Kw	Mt daNm	Pn Kw	Mt daNm	Pn Kw	Mt daNm
30	600	1500	32,01	20,38	24,01	15,29	12,01	7,64	4,00	2,55
	400	1000	21,34	20,38	16,01	15,29	8,00	7,64	2,67	2,55
	300	750	16,01	20,38	12,01	15,29	6,00	7,64	2,00	2,55
	20	50	1,07	20,38	0,80	15,29	1,07	7,64	1,07	2,55

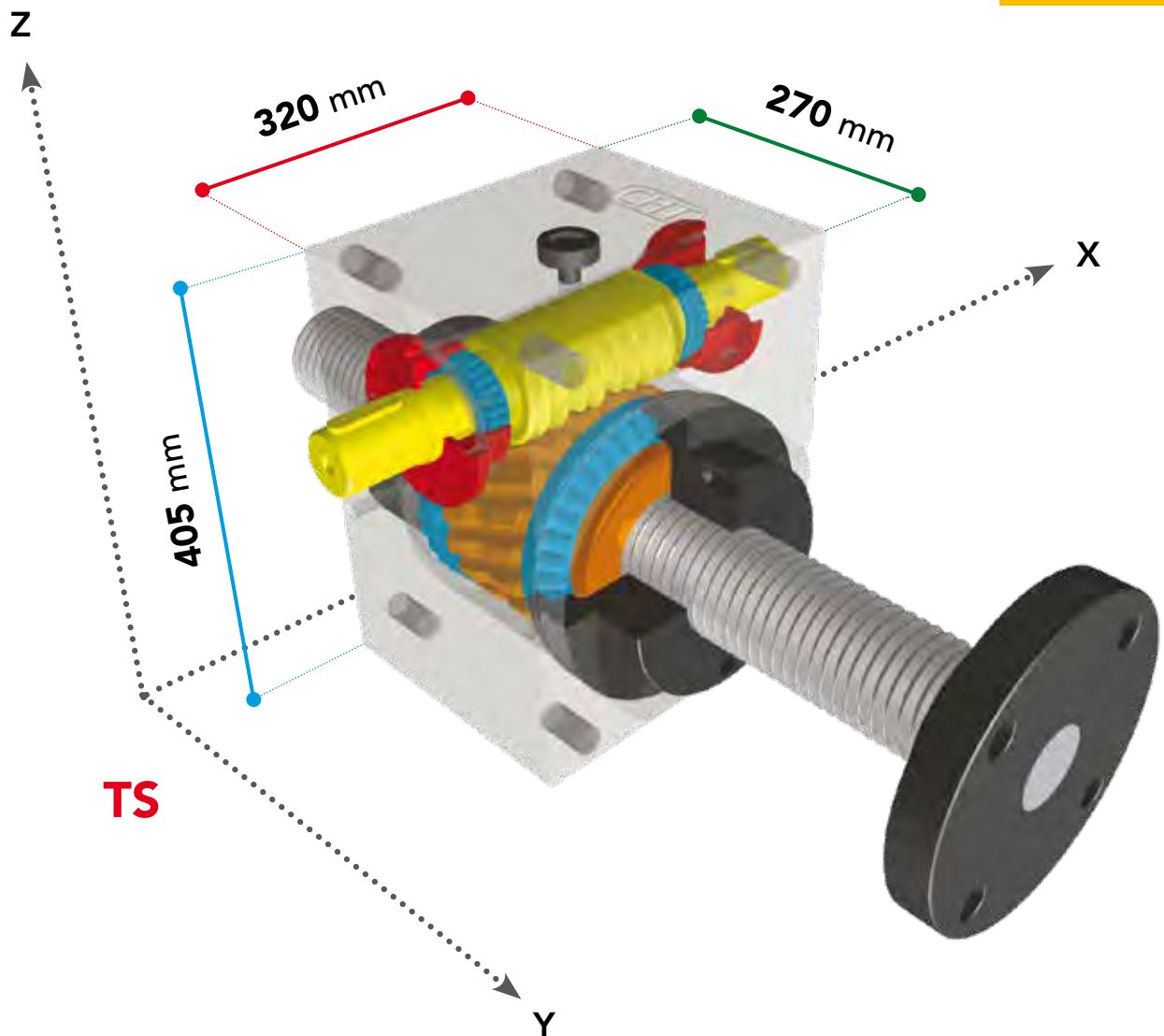

TS

RS



# SERIES CHS 12 TS

# TRANSLATING SCREW

## HEAVY LINE

SERIES CHS 12 TS - 60000 daN · TPN 120x14

SCREW JACK MODEL		CHS 12
LOAD	daN (Kg)	60000
TPN SCREW	DIAMETER mm PITCH mm	120 14
GEAR RATIOS	NORMAL SPEED SLOW SPEED	10:1 30:1
STROKE FOR INPUT REV.	NORMAL SPEED SLOW SPEED	1,4 0,47
EFFICIENCY	NORMAL SPEED SLOW SPEED	17,0% 11,5%
JACK WEIGHT (Kg)		250
SCREW WEIGHT TPN X 100 mm (Kg)		8,1
CASE MATERIAL		Fe 510
GREASE QTY (Kg)		4
GREASE TYPE	AGIP GR MU EP2	
OPERATING TEMPERATURE	-5° C +80° C	

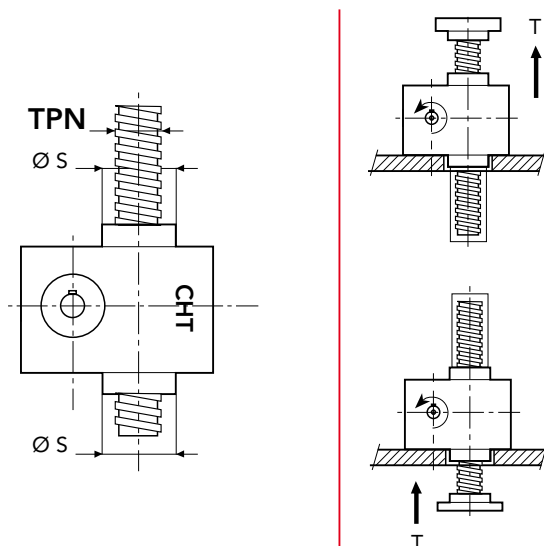
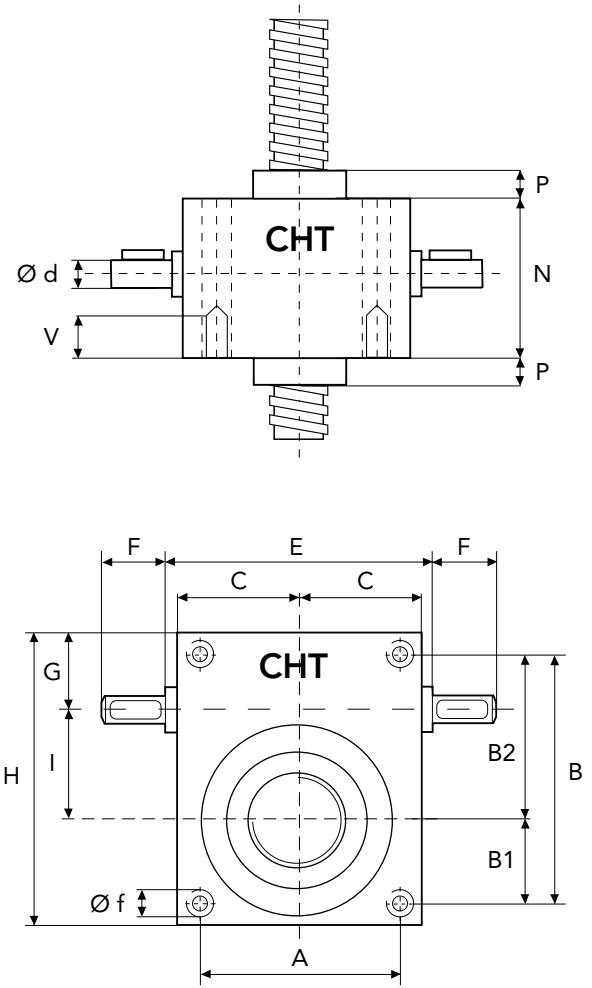

	A	B	B1	B2	C	E	F	G	H
CHS12	230	355	135	220	160	-	85	105	405
	I	N	P	P1	V	Ø d	Ø f	Ø s	TPN
CHS12	140	270	50	40	45	55	M30	210	120x14

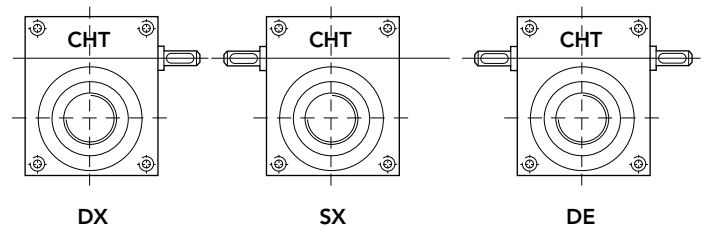



# SERIES CHS 12 RS

# ROTATING SCREW

## HEAVY LINE

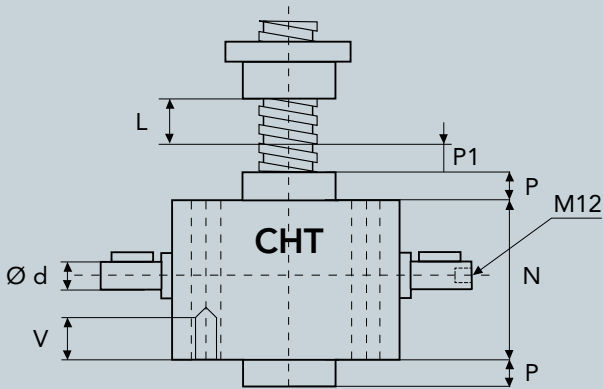

L = CORSA

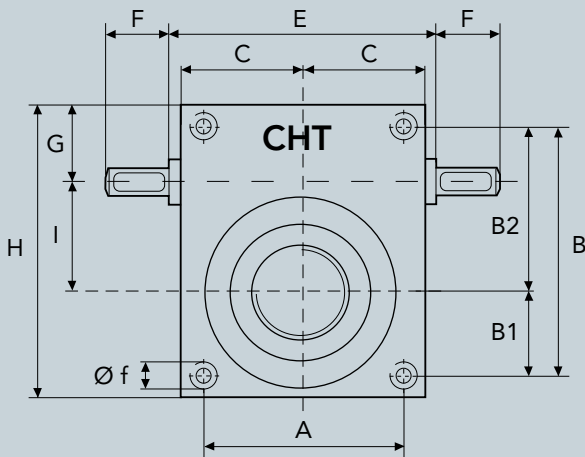

### BRONZE NUT

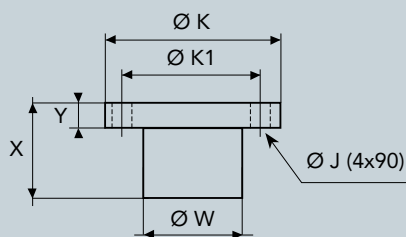

	X	Y	Ø W	Ø K	Ø K1	Ø J
CHS12	160	55	180	280	235	25

### CONFIGURATION

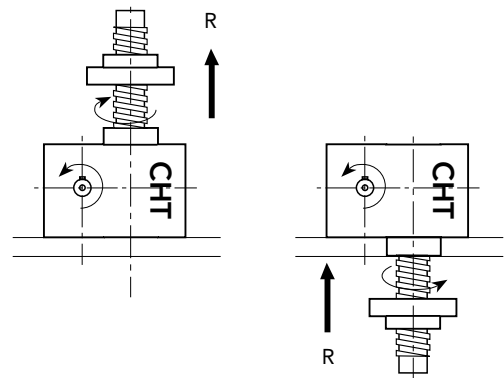
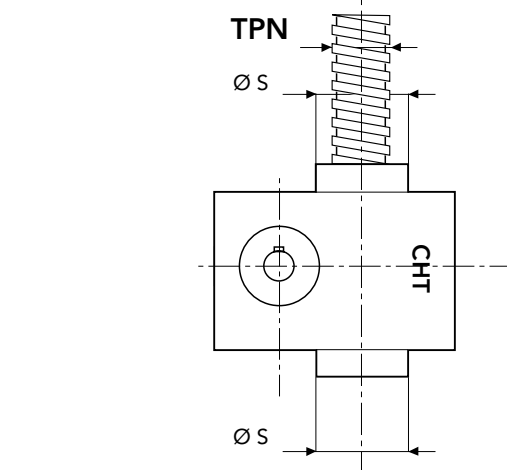

### MOTORS ADAPTORS FLANGES

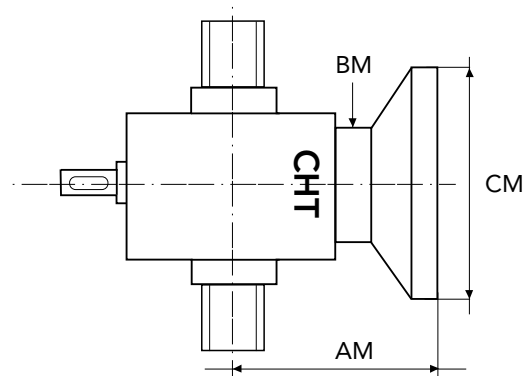

**FOR SPECIAL EXECUTION**  
please consult our technical DPT

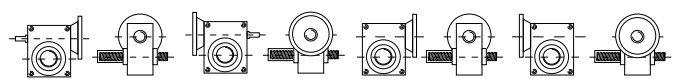

M1

M2

M3

M4

SERIES CHS 12 TS - 60000 daN · TPN 120x14



## SCREW-JACKS WITH BALL SCREWS FOR TRANSLATING SCREW BY INTEGRATED NUT

Consult our technical DPT

SCREW JACK PERFORMANCE SERIES CHS 12

load daN			60000		40000		20000		10000	
ratio	lifting speed mm	input speed	Pn Kw	Mt daNm	Pn Kw	Mt daNm	Pn Kw	Mt daNm	Pn Kw	Mt daNm
10	2100	1500	123,58	76,68	82,39	52,45	41,19	26,23	20,60	13,11
	1400	1000	82,39	76,68	54,93	52,45	27,46	26,23	13,73	13,11
	1050	750	61,79	76,68	41,19	52,45	20,60	26,23	10,30	13,11
	70	50	4,12	76,68	2,75	52,45	1,37	26,23	1,07	13,11

load daN			60000		40000		20000		10000	
ratio	lifting speed mm	input speed	Pn Kw	Mt daNm	Pn Kw	Mt daNm	Pn Kw	Mt daNm	Pn Kw	Mt daNm
30	700	1500	60,90	38,77	40,60	25,85	20,30	12,92	10,15	6,46
	467	1000	40,60	38,77	27,06	25,85	13,53	12,92	6,77	6,46
	350	750	30,45	38,77	20,30	25,85	10,15	12,92	5,07	6,46
	23	50	2,03	38,77	1,35	25,85	1,07	12,92	1,07	6,46

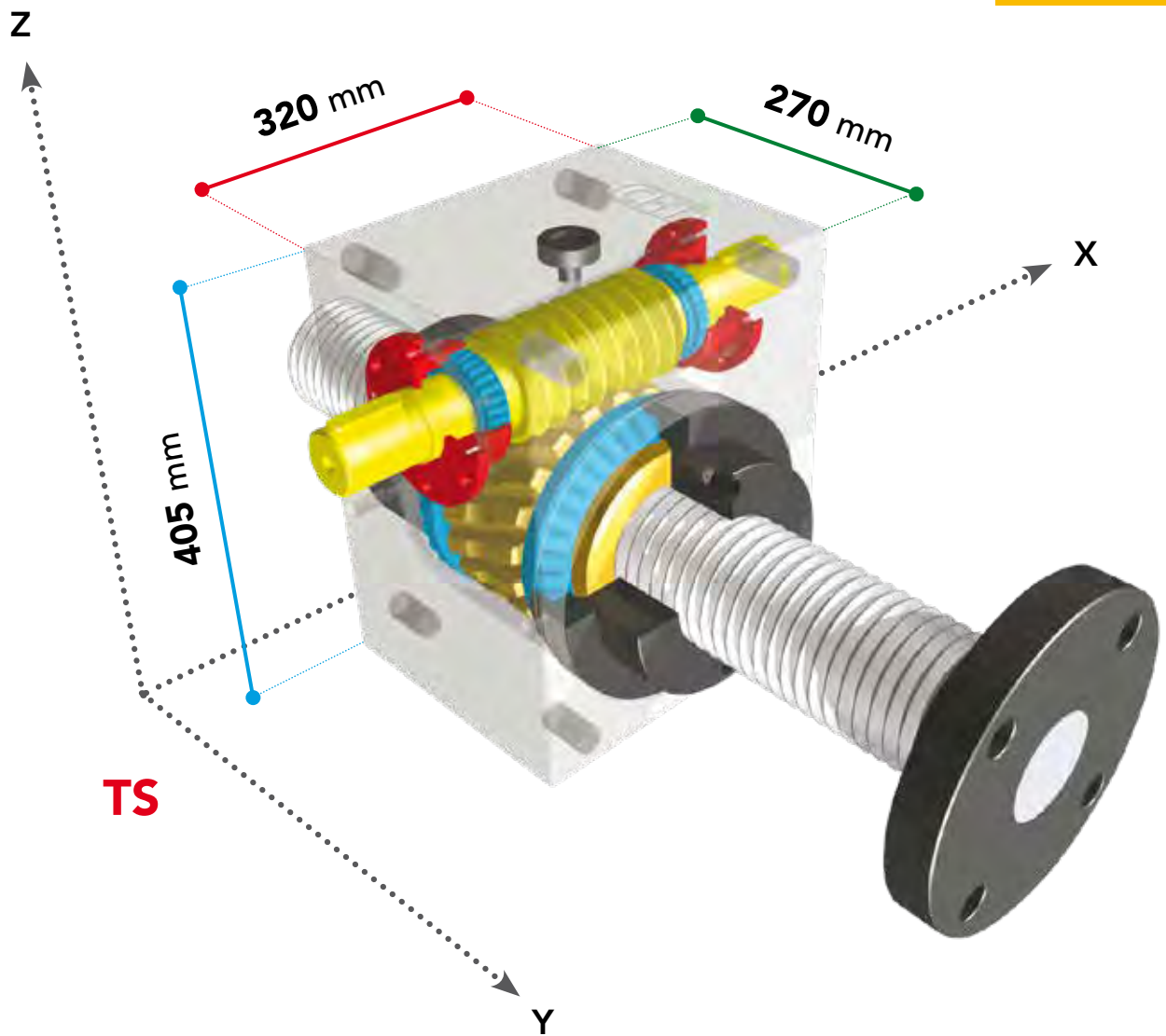

TS

RS



# SERIES CHS 14 TS

# TRANSLATING SCREW

## HEAVY LINE

SERIES CHS 14 TS - 80000 daN · TPN 140x14

SCREW JACK MODEL		CHS 14
LOAD	daN (Kg)	80000
TPN SCREW	DIAMETRO mm PASSO mm	140 14
GEAR RATIOS	NORMAL SPEED SLOW SPEED	12:1 36:1
STROKE FOR INPUT REV.	NORMAL SPEED SLOW SPEED	1,16 0,38
EFFICIENCY	NORMAL SPEED SLOW SPEED	16,0% 10,0%
JACK WEIGHT (Kg)		550
PESO VITE TPNSCREW WEIGHT TPN		
CASE MATERIAL		Fe 510
GREASE QTY (Kg)		14
GREASE TYPE	AGIP GR MU EP2	
OPERATING TEMPERATURE	-5° C +80° C	

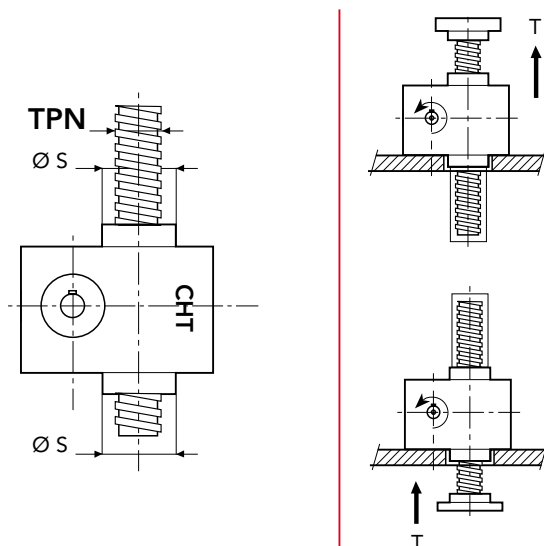
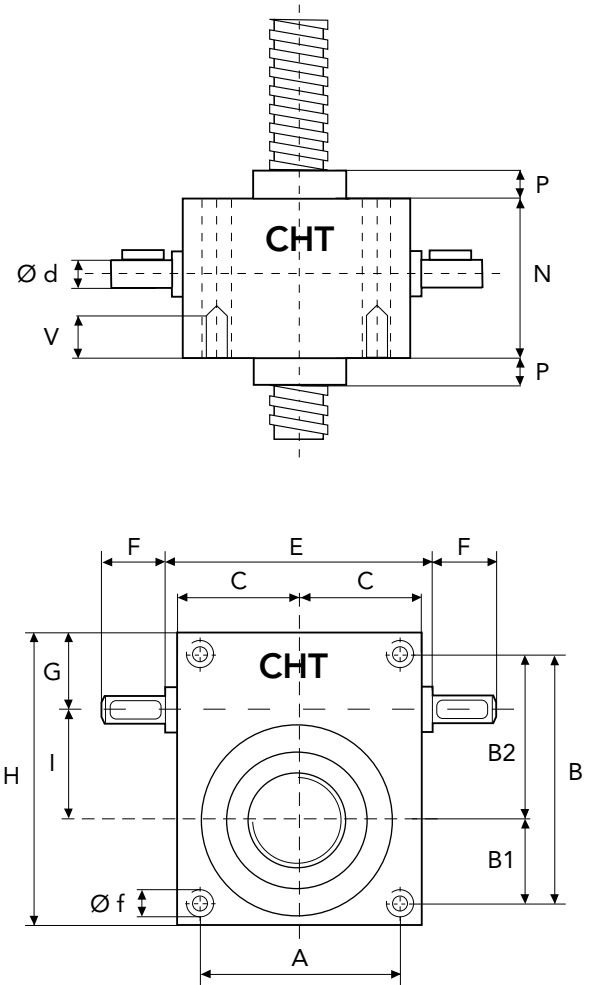

	A	B	B1	B2	C	E	F	G	H
CHS14	360	510	190	320	250	-	140	160	590
	I	N	P	P1	V	Ø d	Ø f	Ø s	TPN
CHS14	200	370	60	50	110	70	M56	300	140x14

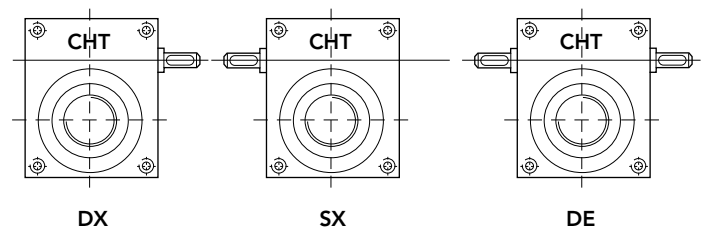



# SERIES CHS 14 RS

# ROTATING SCREW

## HEAVY LINE

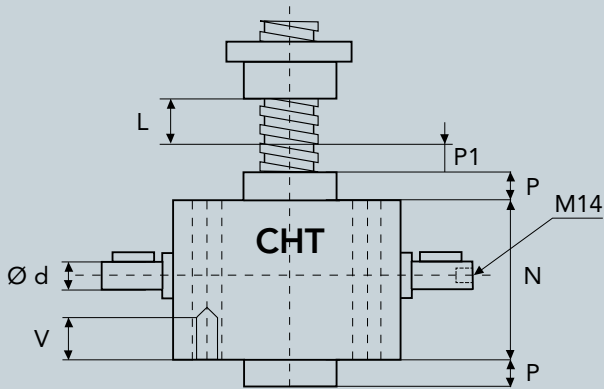

L = CORSA

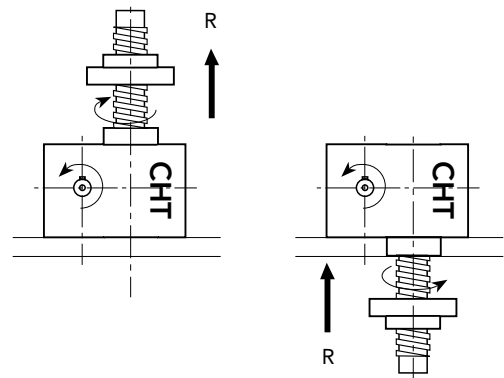
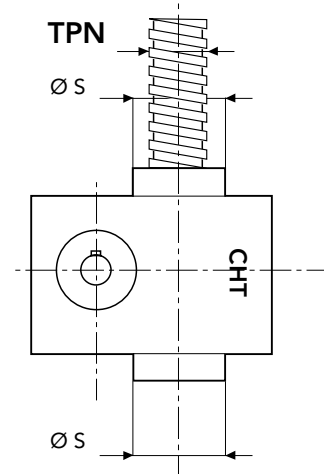
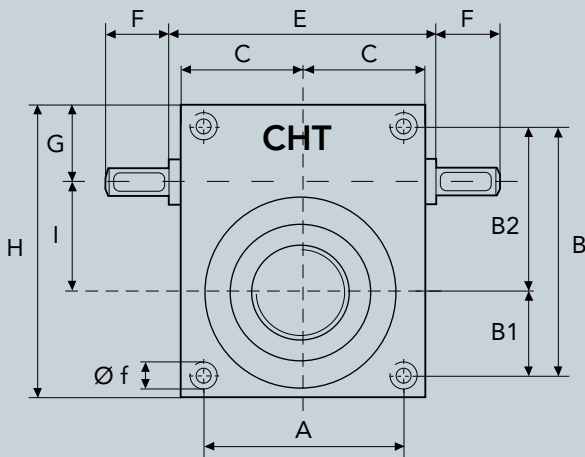

SERIES CHS 14 TS - 80000 daN · TPN 140x14

### BRONZE NUT

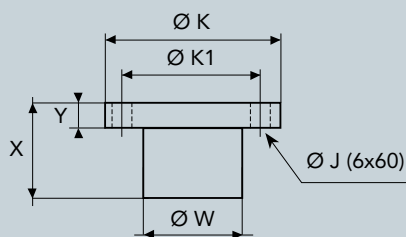

### MOTORS ADAPTORS FLANGES

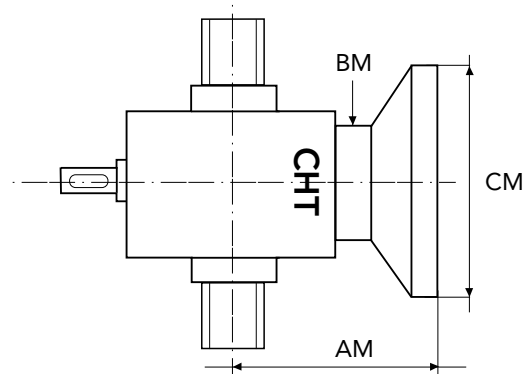

**FOR SPECIAL EXECUTION**  
please consult our technical DPT

	X	Y	Ø W	Ø K	Ø K1	Ø J
CHS14	250	80	210	320	270	25

### CONFIGURATION

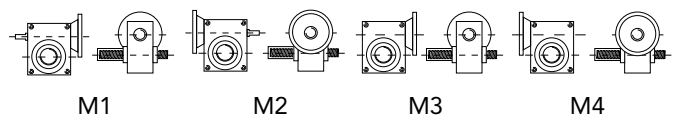



## SCREW-JACKS WITH BALL SCREWS FOR TRANSLATING SCREW BY INTEGRATED NUT

Consult our technical DPT

SCREW JACK PERFORMANCE SERIES CHS 14

load daN			80000		60000		30000		10000	
ratio	lifting speed mm	input speed	Pn Kw	Mt daNm	Pn Kw	Mt daNm	Pn Kw	Mt daNm	Pn Kw	Mt daNm
12	2100	1500	145,90	92,89	109,42	69,67	54,71	34,83	18,24	11,61
	1400	1000	97,26	92,89	72,95	69,67	36,47	34,83	12,16	11,61
	1050	750	72,95	92,89	54,71	69,67	27,36	34,83	9,12	11,61
	70	50	4,86	92,89	13,65	69,67	1,82	34,83	1,07	11,61

load daN			80000		60000		30000		10000	
ratio	lifting speed mm	input speed	Pn Kw	Mt daNm	Pn Kw	Mt daNm	Pn Kw	Mt daNm	Pn Kw	Mt daNm
36	1500	1500	77,81	49,54	58,36	37,15	29,18	18,58	9,73	6,19
	1000	1000	51,87	49,54	38,91	37,15	19,45	18,58	6,48	6,19
	750	750	38,91	49,54	29,18	37,15	14,59	18,58	4,86	6,19
	50	50	2,59	49,54	1,95	37,15	1,07	18,58	1,07	6,19

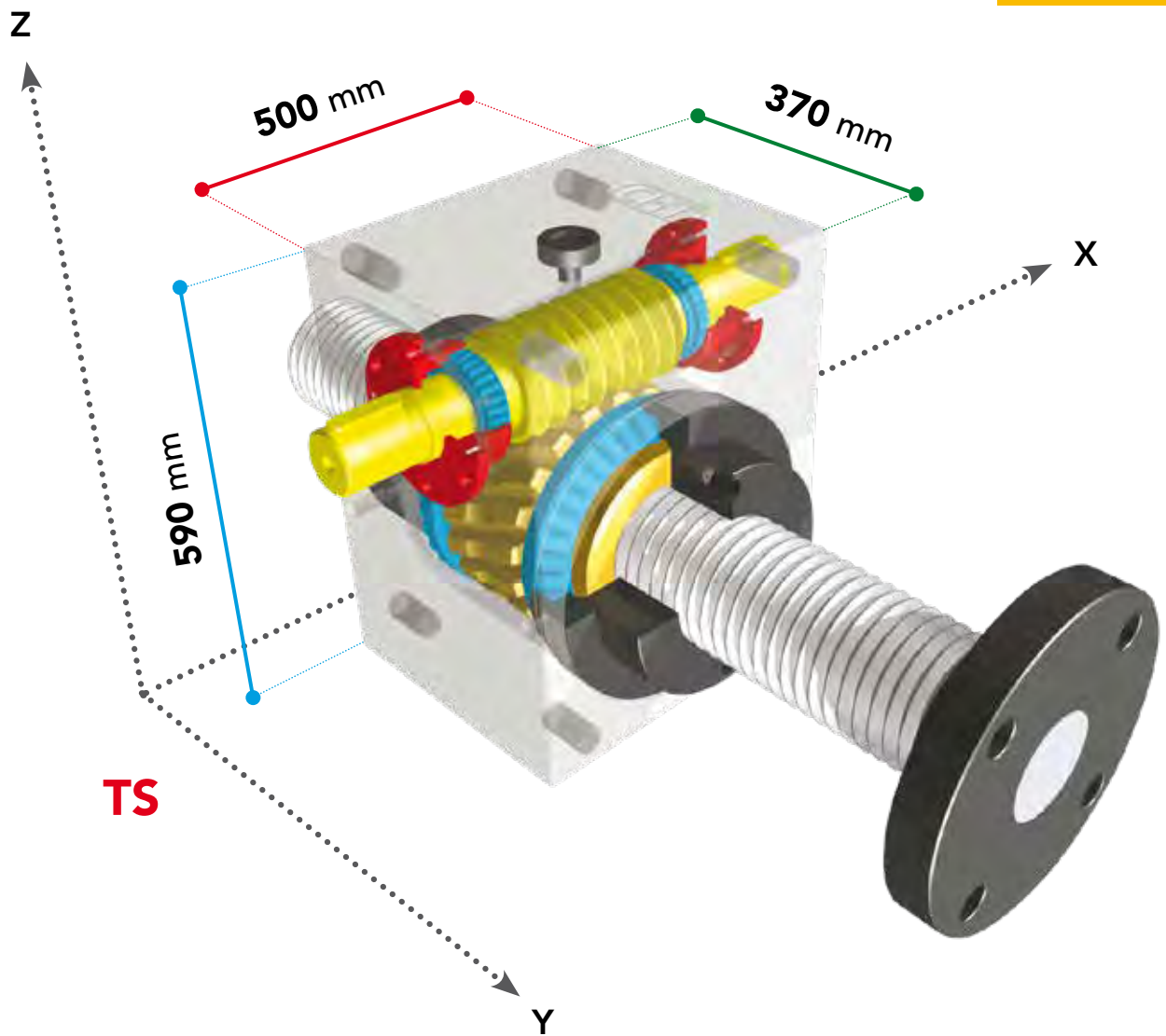

**TS**

**RS**



# SERIES CHS 16 TS

# TRANSLATING SCREW

## HEAVY LINE

SERIES CHS 16 TS - 100.000 daN · TPN 160x16

SCREW JACK MODEL		CHS 16
LOAD	daN (Kg)	100000
TPN SCREW	DIAMETER mm	160
	DIAMETER mm	16
GEAR RATIOS	NORMAL SPEED	12:1
	SLOW SPEED	36:1
STROKE FOR INPUT REV.	NORMAL SPEED	1,33
	SLOW SPEED	0,44
EFFICIENCY	NORMAL SPEED	15,0%
	SLOW SPEED	9,0%
JACK WEIGHT (Kg)		550
SCREW WEIGHT TPN X 100 mm (Kg)		14
CASE MATERIAL		Fe 510
GREASE QTY (Kg)		14
GREASE TYPE	AGIP GR MU EP2	
OPERATING TEMPERATURE	-5° C +80° C	

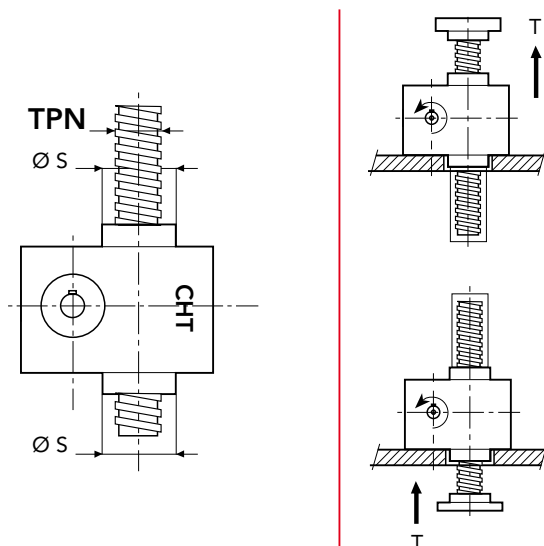
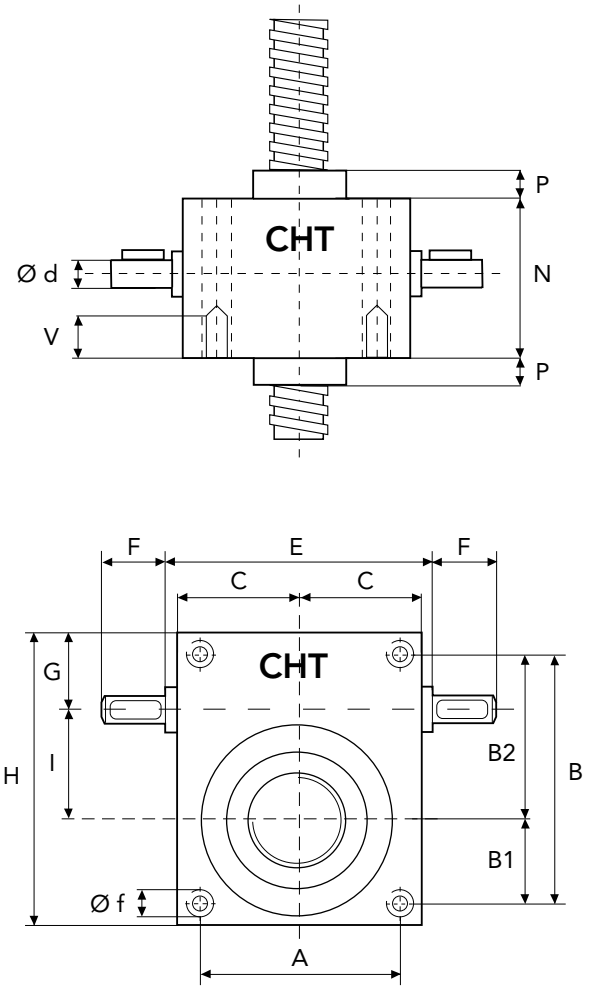

	A	B	B1	B2	C	E	F	G	H
CHS16	360	510	190	320	250	-	140	160	590
	I	N	P	P1	V	$\varnothing d$	$\varnothing f$	$\varnothing s$	TPN
CHS16	200	370	60	50	110	70	M56	300	160x16

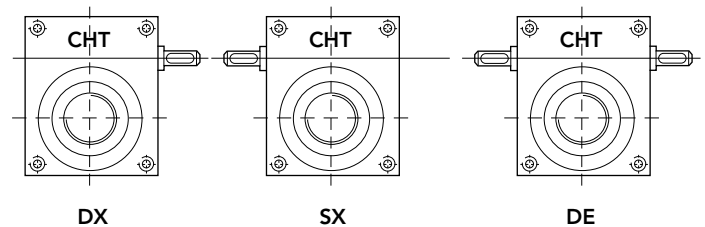



# SERIES CHS 16 RS

# ROTATING SCREW

## HEAVY LINE

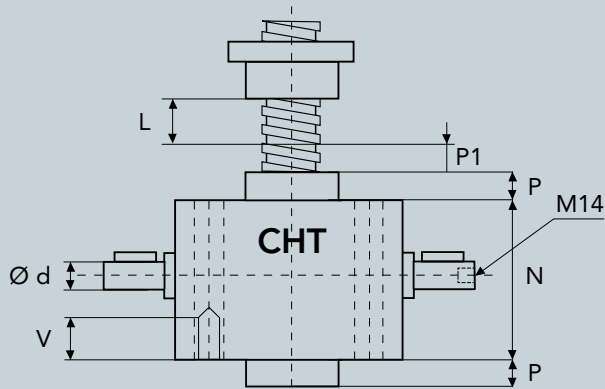

L = CORSA

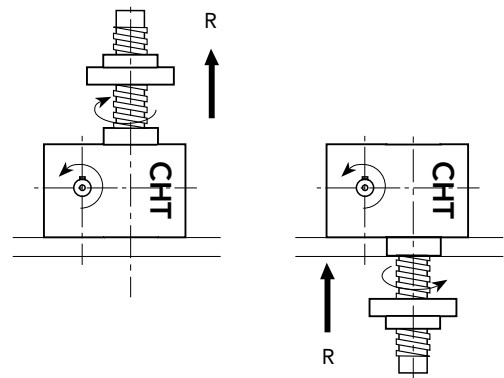
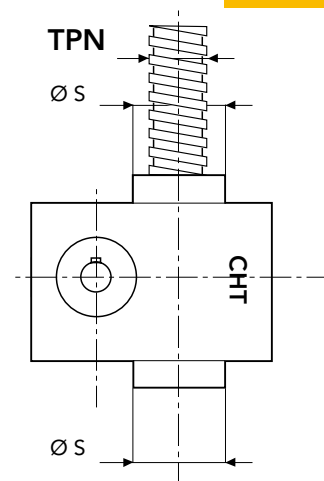
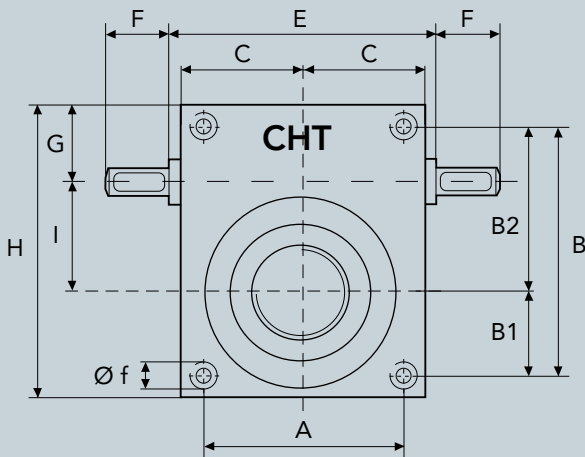

SERIES CHS 16 TS - 100.000 daN · TPN 160x16

### BRONZE NUT

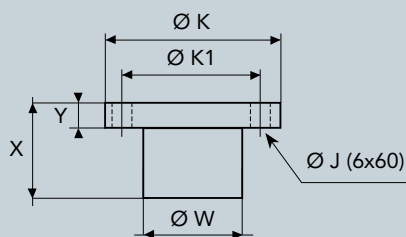

### MOTORS ADAPTORS FLANGES

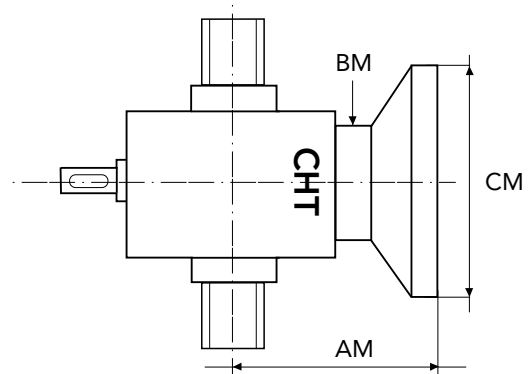

**FOR SPECIAL EXECUTION**  
please consult our technical DPT

	X	Y	Ø W	Ø K	Ø K1	Ø J
CHS16	250	80	210	320	270	25

### CONFIGURATION

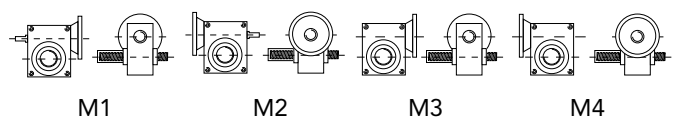



## SCREW-JACKS WITH BALL SCREWS FOR TRANSLATING SCREW BY INTEGRATED NUT

Consult our technical DPT

SCREW JACK PERFORMANCE SERIES CHS 16

load daN			100000		80000		40000		10000	
ratio	lifting speed mm	input speed	Pn Kw	Mt daNm	Pn Kw	Mt daNm	Pn Kw	Mt daNm	Pn Kw	Mt daNm
12	2400	1500	222,32	141,54	177,85	113,23	88,93	56,62	22,23	14,15
	1600	1000	148,21	141,54	118,57	113,23	59,28	56,62	14,82	14,15
	1200	750	111,16	141,54	88,93	113,23	44,46	56,62	11,12	14,15
	80	50	7,41	141,54	5,93	113,23	2,96	56,62	1,07	14,15

load daN			100000		80000		40000		10000	
ratio	lifting speed mm	input speed	Pn Kw	Mt daNm	Pn Kw	Mt daNm	Pn Kw	Mt daNm	Pn Kw	Mt daNm
36	800	1500	123,51	78,63	98,81	62,91	49,40	31,45	12,35	7,86
	533	1000	82,34	78,63	65,87	62,91	32,94	31,45	8,23	7,86
	400	750	61,76	78,63	49,40	62,91	24,70	31,45	6,18	7,86
	27	50	4,12	78,63	3,29	62,91	1,07	31,45	1,07	7,86

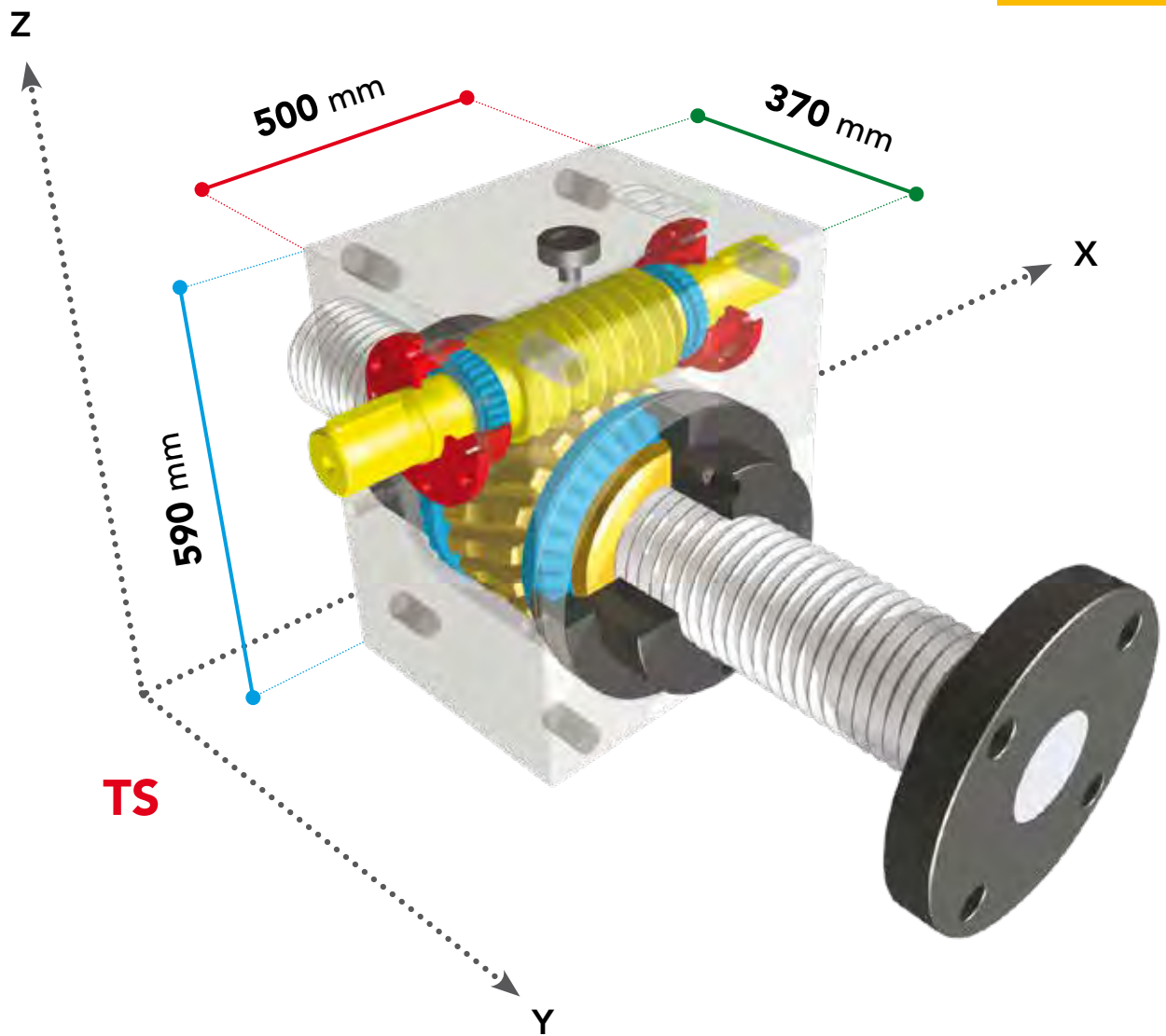

TS

RS



# WORM SCREW JACK WITH BALL SCREW

## INTEGRATED NUT





# FLANGED SINGLE NUT TYPE DIN 69051/5 FOR ROLLED SCREWS

TYPE	$d_o$	$P_h$	$D_w$	N	D	$D_1$	$D_2$	$D_3$	L	$L_1$	$L_2$	$L_3$	$L_4$	$L_5$	H	$C_o$	$C_a$	$R_s$
CHN1405	14	5	3,175	2	24	36	46	5,5	44	5	10	10	40	5	1	846	730	14
CHN1605	16	5	3,175	3	28	38	48	5,5	50	5	10	10	40	5	1	1191	1160	21
CHN1610		10	3,175	3	28	38	48	5,5	55	5	10	10	40	5	1	1191	1160	21
CHN1616		16	3	2	28	38	48	5,5	49	4	12	15	40	6	1	887	783	16
CHN2005	20	5	3,175	4	36	47	58	6,6	54	5	10	10	44	5	1	1985	1525	33
CHN2505	25	5	3,175	4	40	51	62	6,6	54	5	10	10	48	5	1	2691	1626	40
CHN2506		6	3,969	4	40	51	62	6,6	65	6	10	10	48	5	1	3105	2439	41
CHN2510		10	4,762	4	40	51	62	6,6	85	6	10	10	48	5	1	3346	3242	40
CHN2525		25	3,969	2	45	60	73	6,6	72	6	12	15	62	6	1	2383	1872	25
CHN2525-B		25	3,969	3	40	51	62	6,6	95	/	12	30	48	6	1	2940	2458	33
CHN3205	32	5	3,175	4	50	65	80	9	54	6	12	10	62	6	1	3692	1747	50
CHN3206		6	3,969	4	50	65	80	9	65	6	12	10	62	6	1	4221	2618	51
CHN3210		10	6,35	4	50	65	80	9	93	6	12	16	62	6	1	5876	5254	51
CHN3232		32	3,969	3	50	65	80	9	120	/	13	40	62	6,5	1	4270	2642	41
CHN4005	40	5	3,175	5	63	78	93	9	62	6	14	10	70	7	2	5722	2204	71
CHN4010		10	6,35	5	63	78	93	9	106	7	14	16	70	7	2	9377	6611	75
CHN4040		40	6,35	2	70	85	100	9	100	7	14	16	80	7	2	4875	3437	39
CHN5010	50	10	6,35	5	75	93	110	11	108	7	16	16	85	8	2	12714	7050	92

**N** Round of ball

**H** Flange type

**$d_o$**  Nominal diameter (mm)

**$P_h$**  Pitch (mm)

**$D_w$**  Balls diameter (mm)

**$C_o$**  Static load capacity (daN)

**$C_a$**  Dynamic load capacity (daN)

**$R_s$**  Ball stiffness (daN/ $\mu$ m)

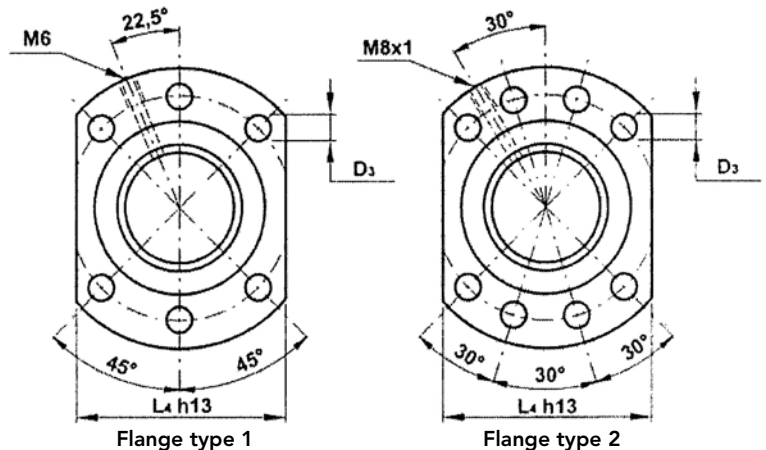
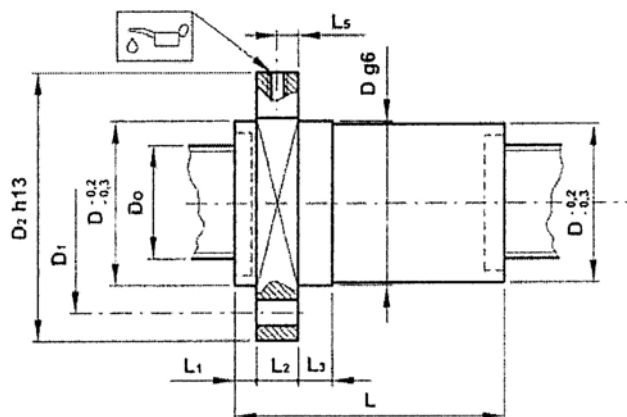



# CHS 2 VRS

Ø 16 BALL SCREW

CHS 2 VRS

		<i>pitch 5</i>	<i>pitch 5</i>		<i>pitch 5</i>		<i>pitch 16</i>	<i>pitch 16</i>		<i>pitch 16</i>	
load daN			500		250			300		150	
ratio	input RPM	lifting speed mm	Pn Kw	Mt daNm	Pn Kw	Mt daNm	lifting speed mm	Pn Kw	Mt daNm	Pn Kw	Mt daNm
5	1500	1500	0,20	0,12	0,10	0,06	4800	0,38	0,24	0,19	0,12
	1000	1000	0,13	0,12	0,07	0,06	3200	0,25	0,24	0,13	0,12
	750	750	0,10	0,12	0,05	0,06	2400	0,19	0,24	0,09	0,12
	50	50	0,01	0,12	0,00	0,06	160	0,01	0,24	0,01	0,12

		<i>pitch 5</i>	<i>pitch 5</i>		<i>pitch 5</i>		<i>pitch 16</i>	<i>pitch 16</i>		<i>pitch 16</i>	
load daN			500		250			300		150	
ratio	input RPM	lifting speed mm	Pn Kw	Mt daNm	Pn Kw	Mt daNm	lifting speed mm	Pn Kw	Mt daNm	Pn Kw	Mt daNm
10	1500	750	0,11	0,07	0,05	0,03	2400	0,20	0,13	0,10	0,06
	1000	500	0,07	0,07	0,04	0,03	1600	0,13	0,13	0,07	0,06
	750	375	0,05	0,07	0,03	0,03	1200	0,10	0,13	0,05	0,06
	50	25	0,00	0,07	0,00	0,03	80	0,01	0,13	0,07	0,06

		<i>pitch 5</i>	<i>pitch 5</i>		<i>pitch 5</i>		<i>pitch 16</i>	<i>pitch 16</i>		<i>pitch 16</i>	
load daN			500		250			300		150	
ratio	input RPM	lifting speed mm	Pn Kw	Mt daNm	Pn Kw	Mt daNm	lifting speed mm	Pn Kw	Mt daNm	Pn Kw	Mt daNm
30	1500	250	0,04	0,02	0,02	0,01		0,07	0,05	0,04	0,02
	1000	167	0,03	0,02	0,01	0,01	533	0,05	0,05	0,02	0,02
	750	125	0,02	0,02	0,01	0,01	400	0,04	0,05	0,02	0,02
	50	8	0,00	0,02	0,00	0,01	27	0,00	0,05	0,00	0,02



# CHS 3 VRS

Ø 32 BALL SCREW

CHS 3 VRS

		<i>pitch 5</i>	<i>pitch 5</i>		<i>pitch 5</i>		<i>pitch 10</i>	<i>pitch 10</i>		<i>pitch 10</i>	
load daN			1000		500			1500		750	
ratio	input RPM	lifting speed mm	Pn Kw	Mt daNm	Pn Kw	Mt daNm	lifting speed mm	Pn Kw	Mt daNm	Pn Kw	Mt daNm
5	1500	1500	0,39	0,25	0,20	0,12	3000	1,18	0,75	0,59	0,37
	1000	1000	0,26	0,25	0,13	0,12	2000	0,78	0,75	0,39	0,37
	750	750	0,20	0,25	0,10	0,12	1500	0,59	0,75	0,29	0,37
	50	50	0,01	0,25	0,01	0,12	100	0,04	0,75	0,02	0,37



# CHS 3 VRS

Ø 32 BALL SCREW

CHS 3 VRS

load daN		<i>pitch 5</i>	<i>pitch 5</i>		<i>pitch 5</i>		<i>pitch 10</i>	<i>pitch 10</i>		<i>pitch 10</i>	
ratio	input RPM	lifting speed mm	Pn Kw	Mt daNm	Pn Kw	Mt daNm	lifting speed mm	Pn Kw	Mt daNm	Pn Kw	Mt daNm
10	1500	750	0,11	0,07	0,05	0,03	1500	0,20	0,13	0,10	0,06
	1000	500	0,07	0,07	0,04	0,03	1000	0,13	0,13	0,07	0,06
	750	375	0,05	0,07	0,03	0,03	750	0,10	0,13	0,05	0,06
	50	25	0,00	0,07	0,00	0,03	50	0,01	0,13	0,00	0,06

load daN		<i>pitch 5</i>	<i>pitch 5</i>		<i>pitch 5</i>		<i>pitch 10</i>	<i>pitch 10</i>		<i>pitch 10</i>	
ratio	input RPM	lifting speed mm	Pn Kw	Mt daNm	Pn Kw	Mt daNm	lifting speed mm	Pn Kw	Mt daNm	Pn Kw	Mt daNm
30	1500	250	0,08	0,05	0,04	0,02	500	0,23	0,14	0,11	0,07
	1000	167	0,05	0,05	0,03	0,02	333	0,15	0,14	0,08	0,07
	750	125	0,04	0,05	0,02	0,02	250	0,11	0,14	0,06	0,07
	50	8	0,00	0,05	0,00	0,02	17	0,01	0,14	0,00	0,07



# CHS 4 VRS

Ø 40 BALL SCREW

CHS 4 VRS

load daN		<i>pitch 5</i>	<i>pitch 5</i>		<i>pitch 5</i>		<i>pitch 10</i>	<i>pitch 10</i>		<i>pitch 10</i>	
ratio	input RPM	lifting speed mm	Pn Kw	Mt daNm	Pn Kw	Mt daNm	lifting speed mm	Pn Kw	Mt daNm	Pn Kw	Mt daNm
5	1500	1500	0,39	0,25	0,20	0,12	3000	1,96	1,25	1,18	0,75
	1000	1000	0,26	0,25	0,13	0,12	2000	1,31	1,25	0,78	0,75
	750	750	0,20	0,25	0,10	0,12	1500	0,98	1,25	0,59	0,75
	50	50	0,01	0,25	0,01	0,12	100	0,07	1,25	0,04	0,75

load daN		<i>pitch 5</i>	<i>pitch 5</i>		<i>pitch 5</i>		<i>pitch 10</i>	<i>pitch 10</i>		<i>pitch 10</i>	
ratio	input RPM	lifting speed mm	Pn Kw	Mt daNm	Pn Kw	Mt daNm	lifting speed mm	Pn Kw	Mt daNm	Pn Kw	Mt daNm
10	1500	750	0,21	0,13	0,11	0,07	1500	1,05	0,67	0,63	0,40
	1000	500	0,14	0,13	0,07	0,07	1000	0,70	0,67	0,42	0,40
	750	375	0,11	0,13	0,05	0,07	750	0,53	0,67	0,32	0,40
	50	25	0,01	0,13	0,00	0,07	50	0,04	0,67	0,02	0,40



# CHS 4 VRS

Ø 40 BALL SCREW

CHS 4 VRS

load daN			pitch 5		pitch 5		pitch 5		pitch 10		pitch 10	
ratio	input RPM	lifting speed mm	Pn Kw	Mt daNm	Pn Kw	Mt daNm	lifting speed mm	Pn Kw	Mt daNm	Pn Kw	Mt daNm	
30	1500	250	0,08	0,05	0,04	0,02	500	0,38	0,24	0,23	0,14	
	1000	167	0,05	0,05	0,03	0,02	333	0,25	0,24	0,15	0,14	
	750	125	0,04	0,05	0,02	0,02	250	0,19	0,24	0,11	0,14	
	50	8	0,00	0,05	0,00	0,02	17	0,01	0,24	0,01	0,14	



# CHS 5 VRS

Ø 50 BALL SCREW

CHS 5 VRS

load daN			pitch 10		pitch 10		pitch 10		pitch 10	
ratio	input RPM	lifting speed mm	Pn Kw	Mt daNm	Pn Kw	Mt daNm	Pn Kw	Mt daNm	Pn Kw	Mt daNm
5	1500	3000	2,35	1,50	1,57	1,00	0,78	0,50	0,39	0,25
	1000	2000	1,57	1,50	1,05	1,00	0,52	0,50	0,26	0,25
	750	1500	1,18	1,50	0,78	1,00	0,39	0,50	0,20	0,25
	50	100	0,08	1,50	0,05	1,00	0,03	0,50	0,01	0,25

load daN			pitch 10		pitch 10		pitch 10		pitch 10	
ratio	input RPM	lifting speed mm	Pn Kw	Mt daNm	Pn Kw	Mt daNm	Pn Kw	Mt daNm	Pn Kw	Mt daNm
10	1500	1500	1,26	0,80	0,84	0,54	0,42	0,27	0,21	0,13
	1000	1000	0,84	0,80	0,56	0,54	0,28	0,27	0,14	0,13
	750	750	0,63	0,80	0,42	0,54	0,21	0,27	0,11	0,13
	50	50	0,04	0,80	0,03	0,54	0,01	0,27	0,01	0,13

load daN			pitch 10		pitch 10		pitch 10		pitch 10	
ratio	input RPM	lifting speed mm	Pn Kw	Mt daNm	Pn Kw	Mt daNm	Pn Kw	Mt daNm	Pn Kw	Mt daNm
30	1500	500	0,45	0,29	0,30	0,19	0,15	0,10	0,08	0,05
	1000	333	0,30	0,29	0,20	0,19	0,10	0,10	0,05	0,05
	750	250	0,23	0,29	0,15	0,19	0,08	0,10	0,04	0,05
	50	17	0,02	0,29	0,01	0,19	0,01	0,10	0,00	0,05





# CONFIGURATIONS

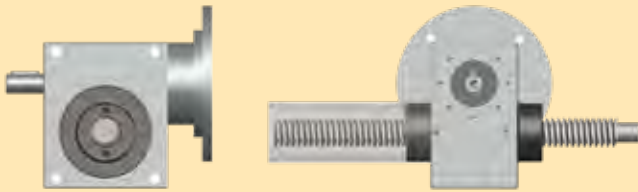

M1



DE

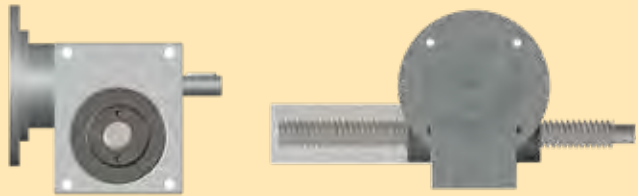

M2



SX



M3

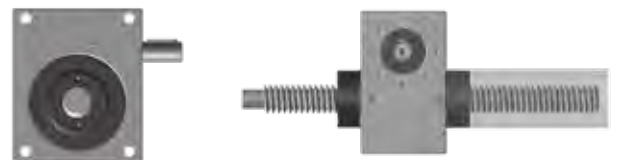

DX



M4



## OPTIONALS

<b>PE</b>	BELLOWS
<b>PR</b>	RIGID COVER PIPE
<b>AR</b>	ANTI-ROTATION
<b>AS</b>	STOP PLATE
<b>FC</b>	LIMIT SWITCH
<b>PO</b>	PIVOTING RIGID COVER
<b>AM</b>	OVERSIZE SCREW
<b>CU</b>	WEAR CONTROL
<b>RG</b>	RECOVER BACKLASH
<b>CS</b>	SAFETY NUTS
<b>FCO</b>	FLANGE FOR PIVOTING FRAME
<b>VRS</b>	BALLSCREW
<b>LO</b>	OIL LUBRICATION
<b>CF</b>	CASE WITH THREAD FIXED HOLE
<b>OX</b>	INOX LIFTING SCREW

## SCREW ENDS

For rotating screw **RS**  
only screw ends type **TL**

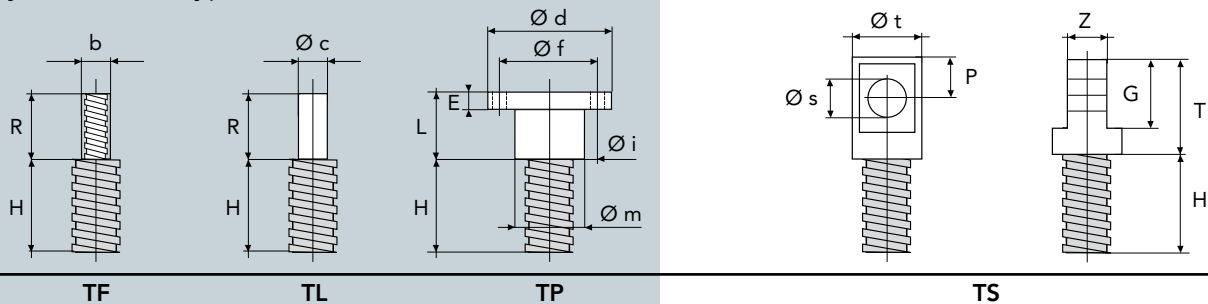

\* N° 4 holes at 90°    \*\* N° 6 holes at 60°     $\text{Øc} = +0 - 0,10$

TYPE	H	R	b	L	E	P	G	T	Z	Øc	Ød	Øf	Øi	Øm	Øs	Øt
<b>CHS 1</b>	15	20	12 x 1.5	14	8	20	40	70	20	12	54	40	7*	26	16	30
<b>CHS 2</b>	15	20	14 x 1.5	21	8	20	40	75	25	15	79	60	11*	39	20	38
<b>CHS 3</b>	20	30	20 x 2.5	23	10	25	50	95	30	20	89	67	11*	46	25	48
<b>CHS 4</b>	25	30	30 x 3.5	30	15	35	70	125	40	30	109	85	13*	60	35	68
<b>CHS 5</b>	25	50	36 x 4	50	20	50	100	180	60	40	149	117	17*	85	50	88
<b>CHS 6</b>	25	50	36 x 4	50	20	50	100	180	60	40	149	117	17*	85	50	88
<b>CHS 7</b>	25	60	56 x 5.5	60	30	60	120	210	75	55	198	155	25*	105	60	108
<b>CHS 8</b>	25	60	64 x 6	60	30	65	130	225	80	65	218	170	25*	120	65	118
<b>CHS 9</b>	40	70	70 x 6	70	40	80	160	280	100	85	278	220	29**	150	80	138
<b>CHS 10</b>	40	70	70 x 6	70	40	80	160	280	100	85	278	220	29**	150	80	138
<b>CHS 12</b>	40	90	90 x 6	80	50	100	200	350	120	100	298	240	32**	170	100	138
<b>CHS 14</b>	50	110	110 x 6	100	60	140	280	450	155	120	378	300	52**	210	140	168
<b>CHS 16</b>	50	125	125 x 6	100	60	140	280	460	155	140	378	300	52**	210	140	216



# OPTIONS

## LIMIT SWITCH

For traslating  
screw TS  
FC type

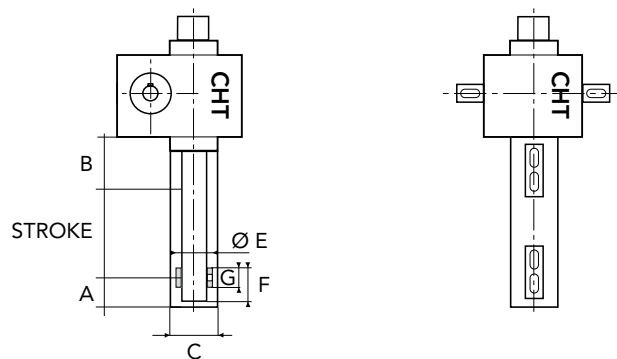
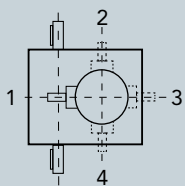

	A	B	Ø C	Ø E	F	G
<b>CHS 1</b>	40	50	40	22	20	16
<b>CHS 2</b>	40	50	48	36	20	18
<b>CHS 3</b>	50	60	65	52	20	20
<b>CHS 4</b>	60	70	76	61	20	20
<b>CHS 5</b>	60	70	102	82	20	20
<b>CHS 6</b>	60	70	102	82	20	20
<b>CHS 7</b>	60	70	128	110	30	30
<b>CHS 8</b>	60	70	128	110	30	30
<b>CHS 9</b>	60	80	Consult our technical DPT		30	30
<b>CHS 10</b>	60	90	229	119	30	30
<b>CHS 12</b>	60	90	229	119	30	30
<b>CHS 14</b>	Consult our technical DPT					
<b>CHS 16</b>	Consult our technical DPT					

## FLANGE FOR PIVOT WORM SCREW JACK (FCO)

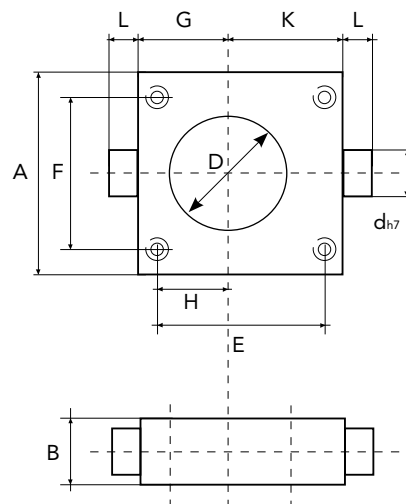

Dim.	CHS SERIES												
	1	2	3	4	5	6	7	8	9	10	12	14	16
<b>B</b>	20	25	30	40	50	50							
<b>Ø dh7</b>	15	20	25	35	45	45							
<b>D</b>	34	48	64	75	100	100							
<b>H</b>	28	30	48	60	60	60							
<b>E</b>	80	85	131	165	175	175							
<b>F</b>	56	80	102	130	134	134							
<b>A</b>	72	98	128	165	175	175							
<b>G</b>	36	38,5	57,5	75	78	78							
<b>K</b>	60	63,5	92,5	125	138	138							
<b>L</b>	15	20	20	30	35	35							



# OPTIONS

## STOP PLATE

For **TS** translating screw **AS** type

GR	A	B
CHS 1	22	16
CHS 2	36	18
CHS 3	52	20
CHS 4	61	20
CHS 5	82	20
CHS 6	82	20
CHS 7	110	30
CHS 8	110	30
CHS 9	Consult our technical DPT	
CHS 10	Consult our technical DPT	
CHS 12	Consult our technical DPT	
CHS 14	Consult our technical DPT	
CHS 16	Consult our technical DPT	

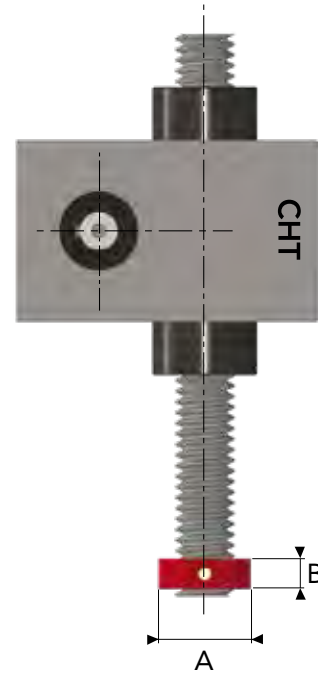

## OVERSIZE SCREW - AM

RS execution only - Rotating screw

For all sizes it is possible to fix screws with oversize diameter and pitch.  
For TS execution translating screw, please consult our Technical office.

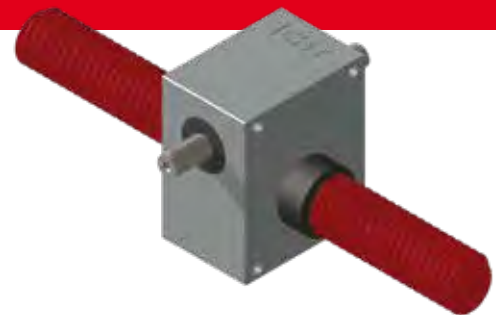

## RG - BACK-LASH RECOVERY

The functioning is based on the role of nuts against nuts. In the **TS** case, the regulation allows to reduce the back lash in the screw jacks. In the **RS** case, it occurs by means of the counter-nut tightening to the nut.

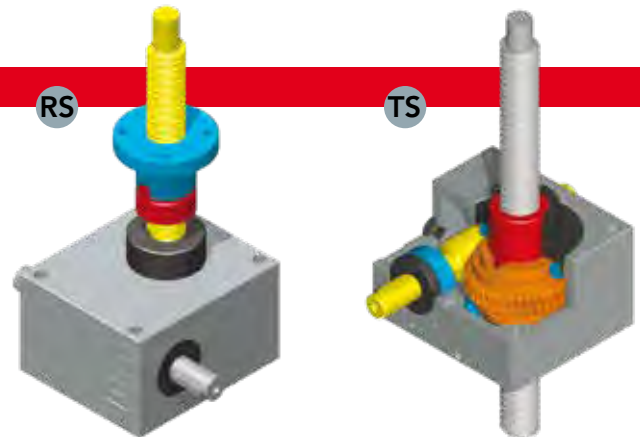

## CU - WEAR AND TEAR CONTROL

The application of an additional nut, just constrained to the helical wheel rotation (in the **TS** case) and to the female screw (in the **RS** case), without being subject to the load, allow to visually check the screw-jack wear.

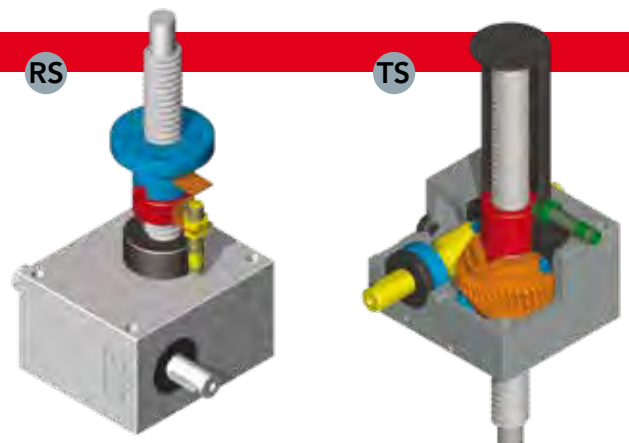



## ANTI-ROTATION

For translating screw TS  
AR type

Double guide anti-rotation realized into the protection tube "PR"

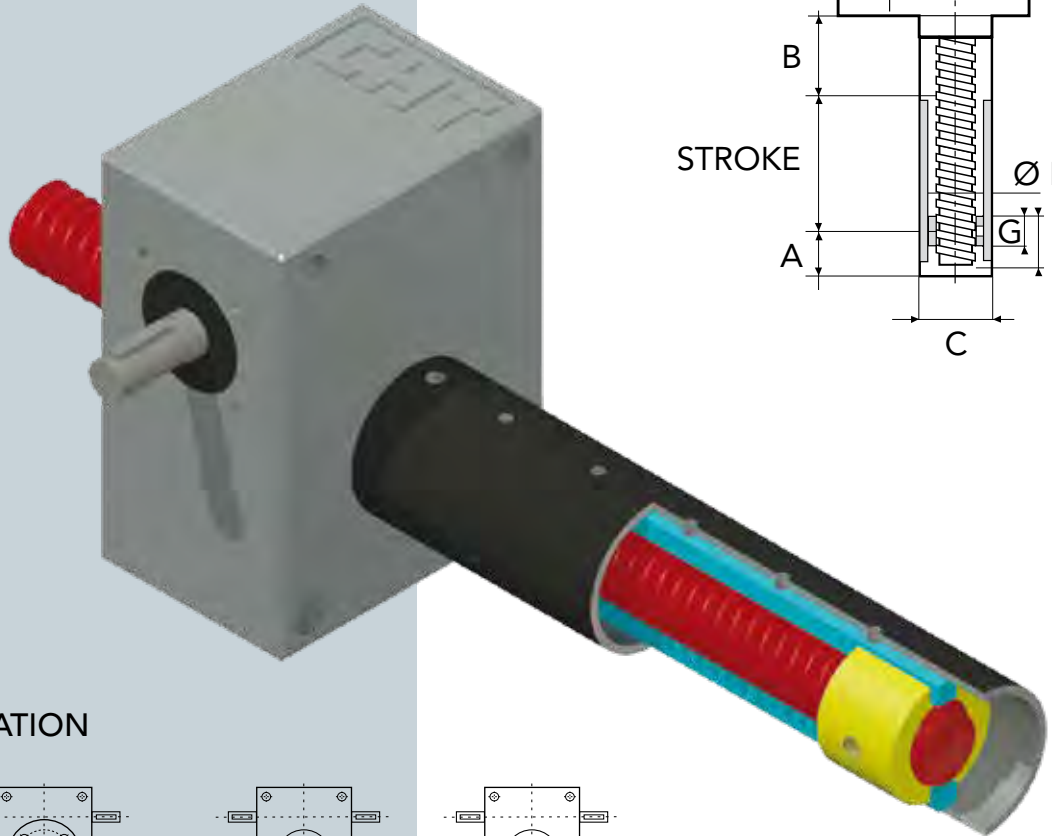

## OUTPUTS ORIENTATION

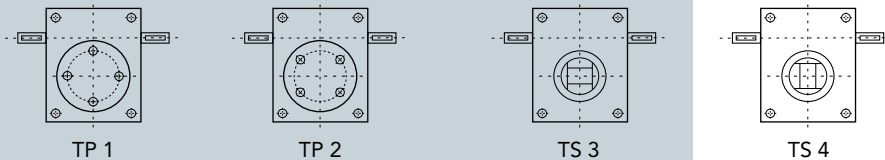

	<b>A</b>	<b>B</b>	<b>Ø C</b>	<b>Ø E</b>	<b>F</b>	<b>G</b>
CHS 1	40	25	40	22	20	16
CHS 2	40	35	48	36	20	18
CHS 3	50	35	65	52	20	20
CHS 4	60	40	76	61	20	20
CHS 5	60	45	102	82	20	20
CHS 6	60	45	102	82	20	20
CHS 7	60	60	128	110	30	30
CHS 8	60	60	128	110	30	30
CHS 9	Consult our technical DPT					
CHS 10	Consult our technical DPT					
CHS 12	Consult our technical DPT					
CHS 14	Consult our technical DPT					
CHS 16	Consult our technical DPT					



# OPTIONS

## PR - PROTECTION TUBE

SIZE	CHS 1	CHS 2	CHS 3	CHS 4	CHS 5	CHS 6	CHS 7	CHS 8	CHS 9	CHS 10	CHS 12	CHS 14	CHS 16
T	40	48	65	76	102	102	128	128	-	-	-	-	-
A	45	55	65	80	85	85	90	90	-	-	-	-	-

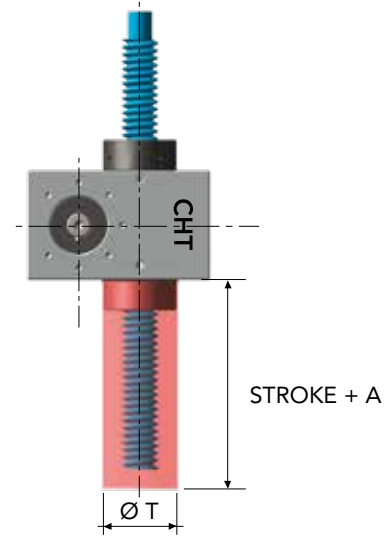

## PROTEZIONE ELASTICA - PE

SIZE	CHS 1	CHS 2	CHS 3	CHS 4	CHS 5	CHS 6	CHS 7	CHS 8	CHS 9	CHS 10	CHS 12	CHS 14	CHS 16
L	1/10 of the stroke (completely closed)												
L1	stroke												
B	30	44	60	69	90	90	120	120	150	210	210	300	300
C	26	32	46	60	85	85	120	120	150	150	180	210	210
D	15	15	15	20	30	30	30	30	50	50	50	60	60
E	70	70	78	120	120	120	145	145	145	225	225	265	265

**NOTE** Round up the stroke to 100 mm over

SCREW JACK WITH  
TRANSLATING SCREW.  
RIGID COVER.  
SENSOR CONTROL  
FOR STROKE.  
FLEXIBLE COVER.



OPEN

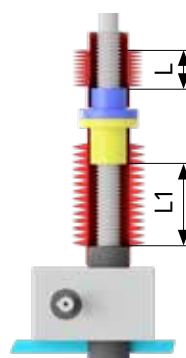

CLOSED

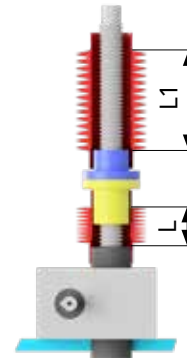

ROTATING VERSION

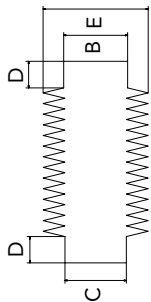

CLOSED

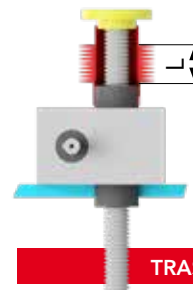

OPEN

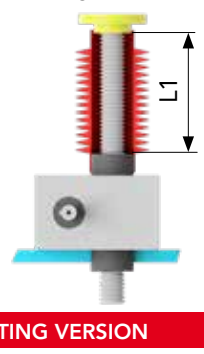

TRASLATING VERSION



# SPARE PARTS

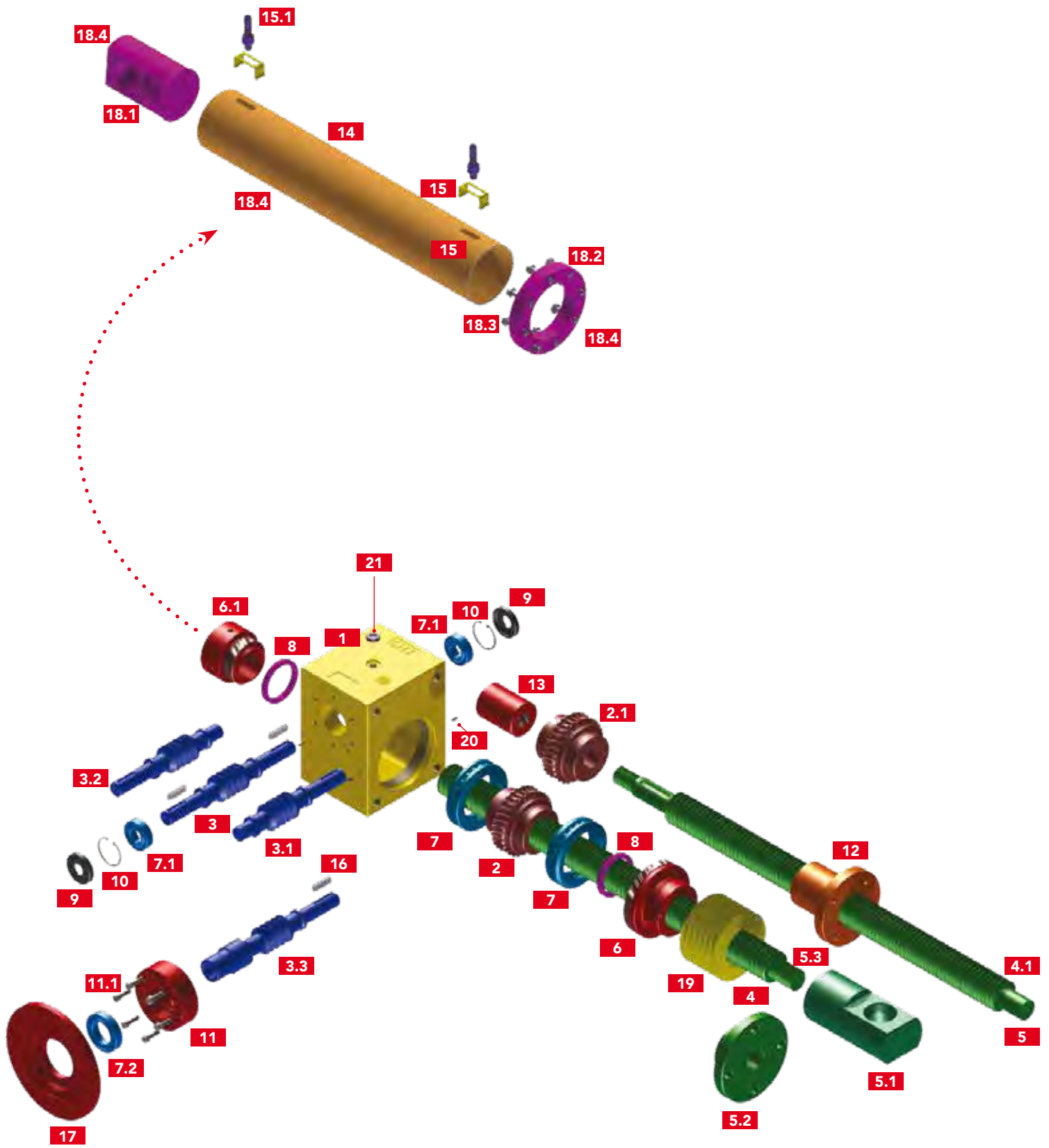



# SPARE PARTS



- 1** HOUSING
- WORM WHELL **2**
- 2.1** ROTATING WORM WHEEL
- WORM SCREW **DE** **3**
- 3.1** WORM SCREW **DX**
- WORM SCREW **SX** **3.2**
- 3.3** WORM SCREW **PAM**
- WORM SCREW BEARING **TS** **4**
- 4.1** WORM WHEEL BEARING **RS**
- TL** CYLINDRICAL END SHAFT **5**
- 5.1** TERMINAL SWINGING JOINT **TS**
- FLAT PLATE TERMINAL **TP** **5.2**
- 5.3** THREADED TERMINAL **TF**
- TOP COVER **6**
- 6.1** BOTTON COVER
- BEARING WORM WHEEL **7**
- 7.1** **VSF** BEARING
- VSF PAM** BEARING **7.2**
- 8** **V RING** SEAL
- SEALING RING **9**
- 10** SEEGER
- BEARING PILLOW **11**
- 11.1** **PAM** FLANGE LOCKING SCREW
- BRONZE NUT **12**
- 13** LOCKING BLOCK ROTATING SCREW
- PR** RIGID COVER **14**
- 15** **FC** PREDISPOSITION
- PROXIMITY SENSOR **15.1**
- 16** KEY
- PAM** FLANGE **17**
- 18.1** **PO** END SWINGING RIGID COVER
- PO** CLAMPING FLANGE **18.2**
- 18.3** **PO** CLAMPING BOLT FLANGE
- PO** SWINGING RIGID COVER **18.4**
- 19** **PE** ELASTIC COVER
- CLAMPING GRUB SCREW **20**
- 21** FAT PLUG



# CS - SAFETY NUT

Many applications need the certainty that the screw-jack can bear the loading also when the nut (meant as worm wheel or nut) is worn out. The safety nut couples of the main nut with a frontal key.

In case of wear the main nut, the distance between the two nuts decreases.

This wear causes the reduction of the L or L1 dimension (it depends on the model type, i.e. TS or RS type).

When such a decreasing reaches a  $\varnothing$  value, stated in the table, it is strictly necessary to replace the main and the safety nuts: **therefore, this value is to be periodically checked.**

Please also take into account that the safety nut works only in one direction (so either by traction or by compression).

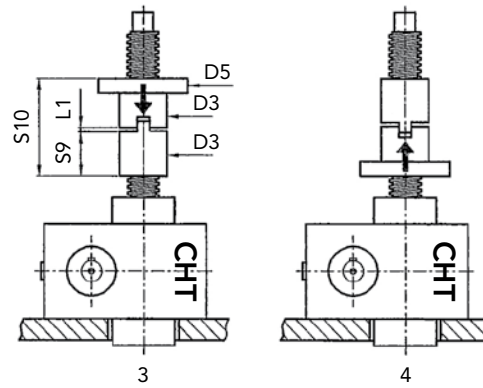
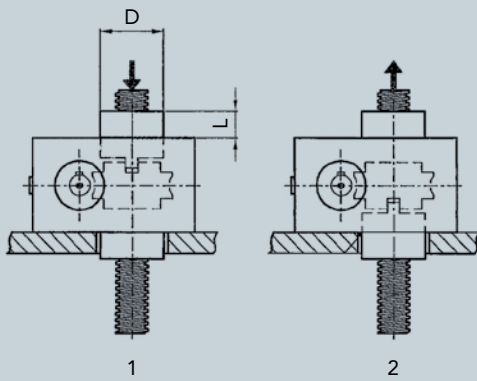
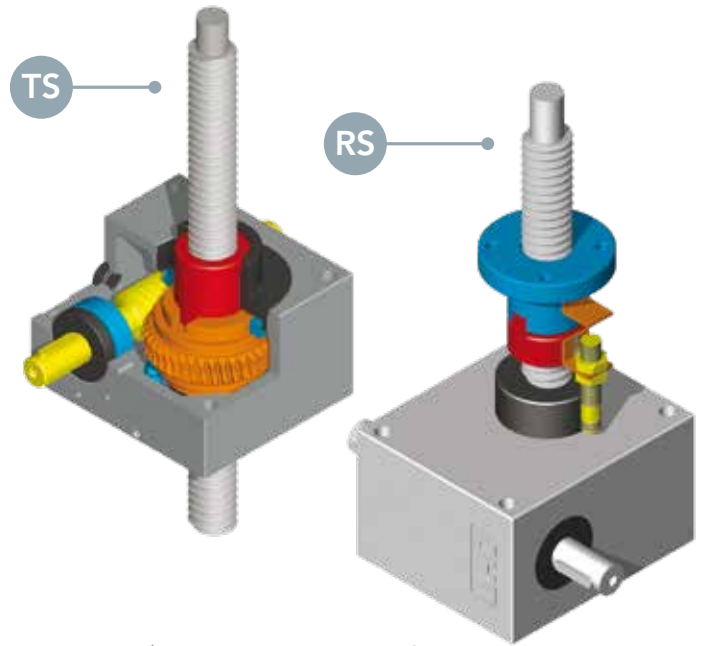

## SAFETY NUT - CS - FOR TS MODELS

SIZE	CHS 1	CHS 2	CHS 3	CHS 4	CHS 5	CHS 6	CHS 7	CHS 8	CHS 9	CHS 10	CHS 12	CHS 14	CHS 16
Wearing limit value $\varnothing$	Consult our technical DPT	1	1,5	1,75	2,25	2,25	2,5	2,5	Consult our technical DPT				
D $\varnothing$	Consult our technical DPT	40	52	65	82	82	100	110	Consult our technical DPT				
L~	Consult our technical DPT	17	20	32	42	42	58	63	Consult our technical DPT				

## SAFETY NUT - CS - FOR RS MODELS

SIZE	CHS 1	CHS 2	CHS 3	CHS 4	CHS 5	CHS 6	CHS 7	CHS 8	CHS 9	CHS 10	CHS 12	CHS 14	CHS 16
Wearing limit value $\varnothing$	Consult our technical DPT	1	1,5	1,75	2,25	2,25	2,5	2,5	Consult our technical DPT				
D3 $\varnothing$	Consult our technical DPT	32	46	60	76	80	100	110	Consult our technical DPT				
D5 $\varnothing$	Consult our technical DPT	60	80	96	130	110	180	190	Consult our technical DPT				
L1~	Consult our technical DPT	2	3	3,5	4,5	4,5	5	5	Consult our technical DPT				
S9	Consult our technical DPT	35	38	64	89	89	90	95	Consult our technical DPT				
S10	Consult our technical DPT	82	89	142,5	193,5	193,5	200	210	Consult our technical DPT				



## PIVOTING RIGID PROTECTION - PO

For TP models, we offer a rigid cover with rod end. Since this cover bears the loading, it is advisable not to exceed with the length, to avoid any anomalous flexion.

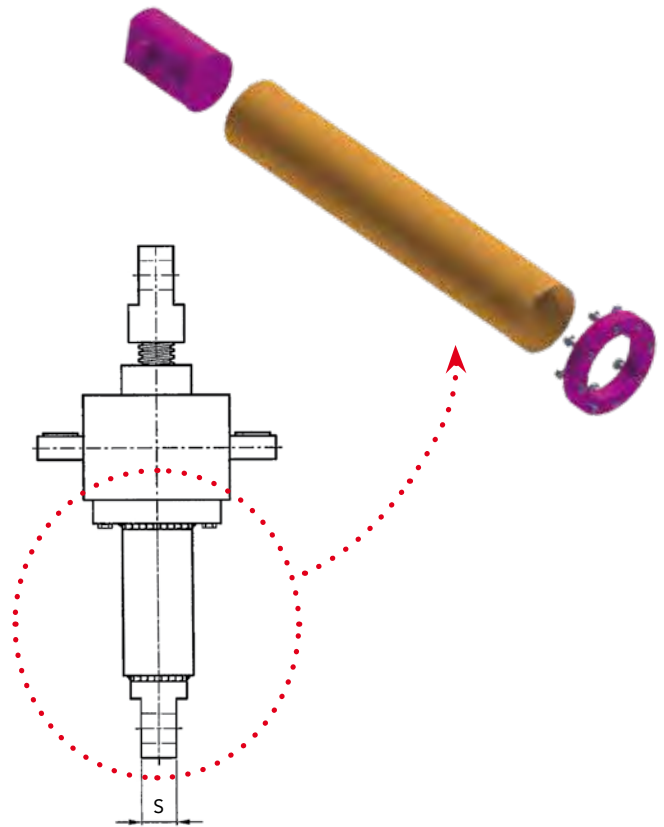
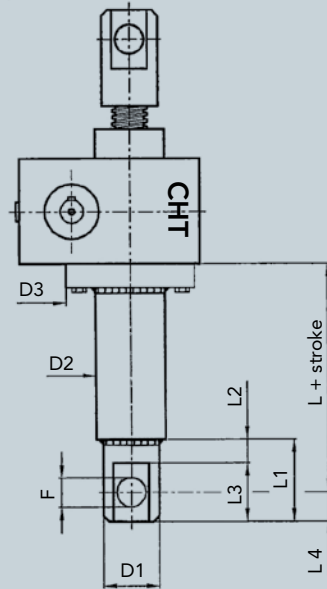

## PIVOTING RIGID PROTECTION - PO

SIZE	CHS 1	CHS 2	CHS 3	CHS 4	CHS 5	CHS 6	CHS 7	CHS 8	CHS 9	CHS 10	CHS 12	CHS 14	CHS 16
D1 ø	Consult our technical DPT	38	48	68	88	88	118	118	Consult our technical DPT				
D2 ø	Consult our technical DPT	48	65	76	102	102	128	128	Consult our technical DPT				
D3 ø	Consult our technical DPT	88	110	150	150	150	200	200	Consult our technical DPT				
F ø H9	Consult our technical DPT	20	25	35	50	50	60	60	Consult our technical DPT				
L	Consult our technical DPT	90	115	145	180	180	215	215	Consult our technical DPT				
L1	Consult our technical DPT	55	70	95	140	140	175	175	Consult our technical DPT				
L2	Consult our technical DPT	15	20	25	40	40	45	45	Consult our technical DPT				
L3	Consult our technical DPT	40	50	70	100	100	130	130	Consult our technical DPT				
L4	Consult our technical DPT	20	25	35	50	50	65	65	Consult our technical DPT				
L5	Consult our technical DPT	15	20	20	20	20	25	25	Consult our technical DPT				
S	Consult our technical DPT	25	30	40	60	60	80	80	Consult our technical DPT				



# MOUNTING EXAMPLES



2.0

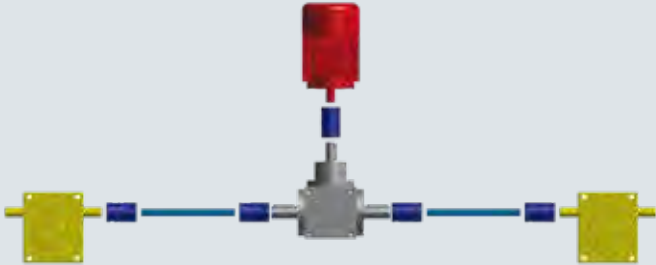

2.1



2.2

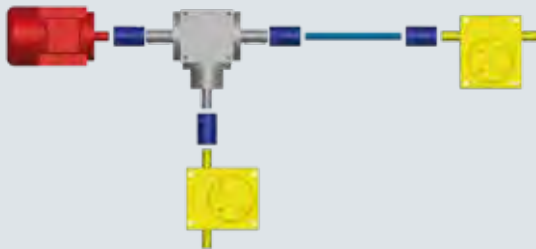

2.3



2.4

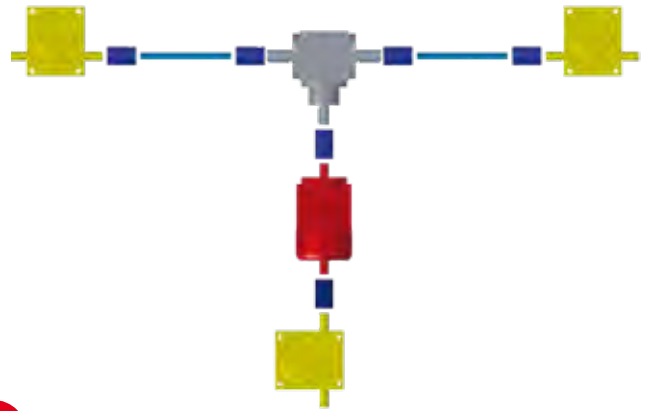

3.1

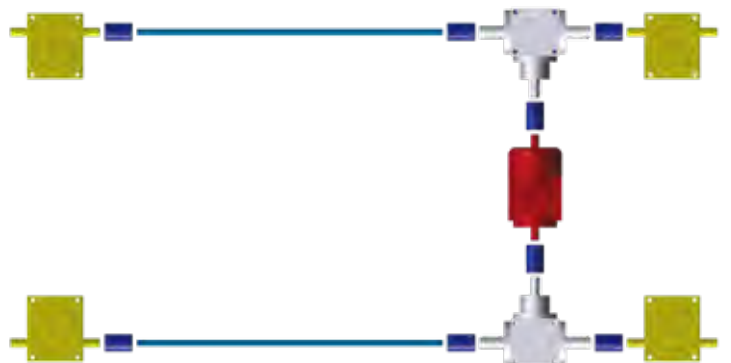

4.1

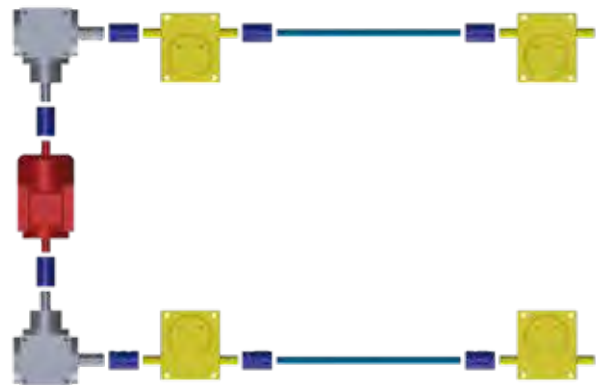

4.2

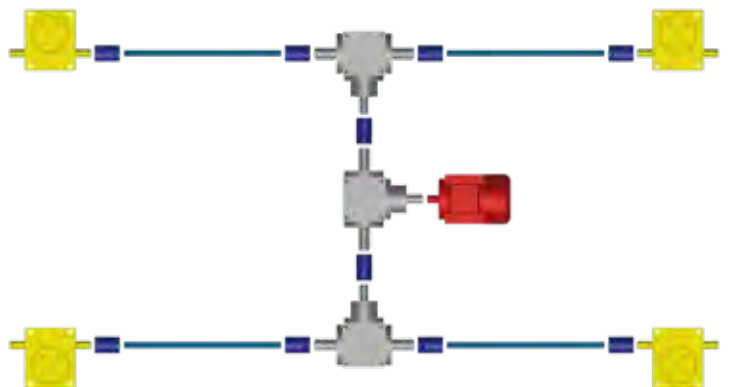

4.3



# MOUNTING EXAMPLES

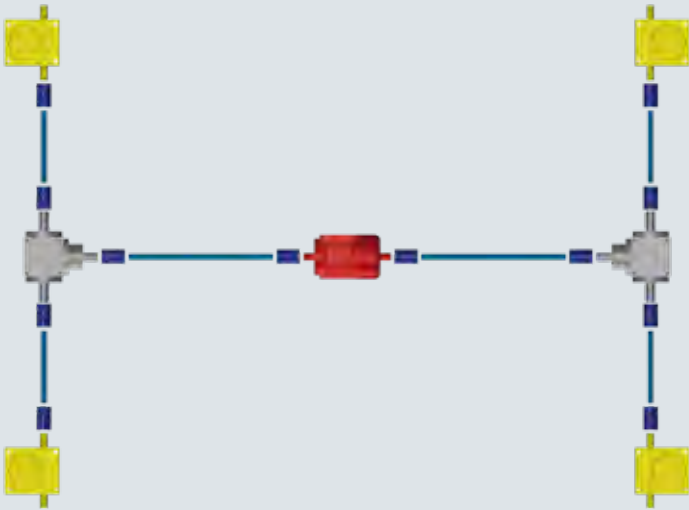

4.4

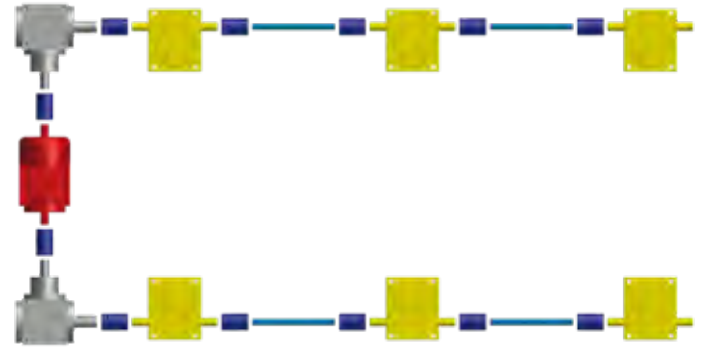

6.2

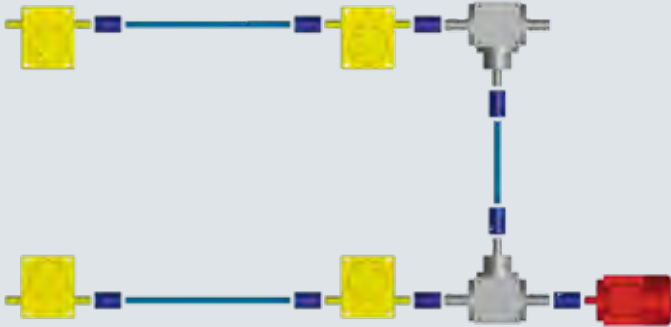

4.5

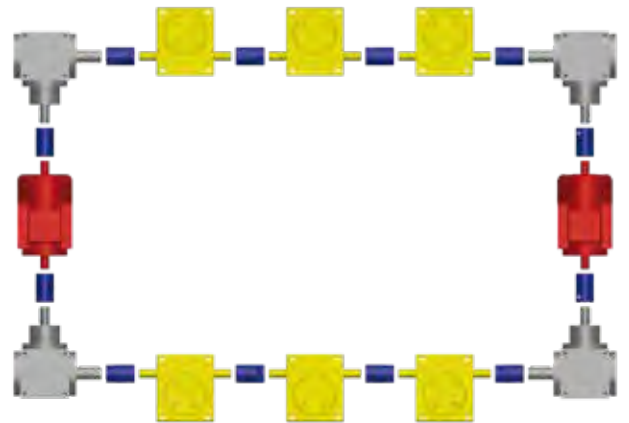

6.3

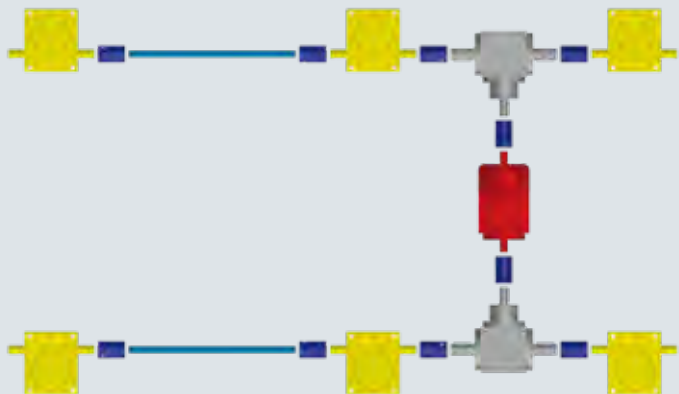

6.1

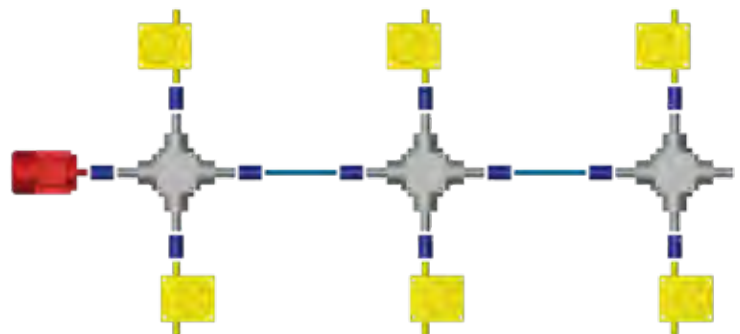

6.4



## GENERAL SALES CONDITIONS

**1) ORDERS** - Orders for special and standard material must always refer to offers made by CHIARAVALLI GROUP S.p.A. The orders are binding for the client.

Once work has commenced no cancellations or order reductions will be accepted unless the client reimburses the costs of the material and the work carried out up to the moment in which the order was suspended.

The quantity despatched can vary by  $\pm 5\%$  compared to the quantity ordered.

**2) PRICES** - The prices are those in force at the date of order.

All prices are for goods delivered ex-works Premezzo, packing excluded. If there should be any increase in production and material costs over the duration of the supply, CHIARAVALLI GROUP S.p.A. reserves the right to adapt the prices accordingly, even for orders in course.

**3) TERMS OF DELIVERY** - Only the terms of delivery indicated by CHIARAVALLI GROUP SpA are to be considered valid. However, they must only be considered as indicative.

In the event of difficulty in the procurement of materials, strikes or in any event in all cases of force majeure, the terms of delivery will be automatically extended without CHIARAVALLI GROUP S.p.A. having to pay any reimbursement for damages.

The client is obligated to collect special material ordered when ready.

**4) DELIVERIES** - Deliveries are the responsibility of the purchaser and are carried out at his own risk and peril.

Any claims for shortages must be presented within 8 days of receipt of the goods.

If it is agreed that the cost of transport is to be paid, even if only in part, by CHIARAVALLI GROUP S.p.A., the latter reserves the right to choose the most economical means of transport.

**5) PACKING** - Packing will be invoiced at cost.

**6) RETURNS** - No returns for any reason will be accepted unless previously authorised and with packing, any customs clearance and the return paid for by the purchaser.

To cover warehouse and administrative expenses a debit note will be issued for approx. 15% of the value of the goods returned.

**7) WARRANTY** - CHIARAVALLI GROUP S.p.A. promises to repair or substitute free of charge any parts that they recognise as being defective. The questioned goods must be returned to the factory of CHIARAVALLI GROUP S.p.A., free of all expenses.

The warranty will be considered cancelled in the event that the parts returned as defective have been repaired or tampered with. The repair of defective parts carried out by the purchaser will only be accepted after authorisation from CHIARAVALLI GROUP S.p.A. and after their approval of the cost estimate. CHIARAVALLI GROUP S.p.A. does not accept responsibility or pay any reimbursement for damages that occur during the use of their products, even if defective.

Warranty is excluded for leakage of lubricant caused by wear of the oil seals.

**8) RESPONSIBILITY** - CHIARAVALLI GROUP S.p.A. does not accept responsibility or pay any reimbursement for damages that occur during the use of their products, even if defective.

CHIARAVALLI GROUP S.p.A. declines all responsibility in the execution of parts to a client's design under any patents.

**9) PAYMENTS** - Only payments carried out in the manner and terms agreed will be considered valid. Once the due date of payment has passed, CHIARAVALLI GROUP S.p.A. will calculate the interest on delayed payment at a rate that is 3% higher than the legal one, retaining the right to demand payment. In the event of delayed or missing payment by the purchaser, the company CHIARAVALLI GROUP S.p.A. reserves the right to suspend deliveries of the orders in course or to demand advance payment without having to pay any reimbursement or compensation to the purchaser. Any dispute regarding materials in manufacture or already possessed by the purchaser does not free the latter from the commitment of making the payment by the agreed date and for the whole amount of the invoice without making any deductions.

**10) OWNERSHIP** - All of the goods despatched remain the property of CHIARAVALLI GROUP S.p.A. until the invoice is fully paid.

**11) COMPETENT COURT** - Any controversy concerning business relations with CHIARAVALLI GROUP SpA will be dealt with under the jurisdiction of the Court of Busto Arsizio.

CHIARAVALLI GROUP SpA, do not accepts responsibility for any errors in the production of this catalogue and reserves the right to add to the drawings designs of the listed products any modification request by manufacturing requirements or due to evolution of the products.



*Cavaria con Premezzo*  
*21044 - Varese - ITALY*  
*Via per Cedrate, 476 - P.O. 10*  
*Tel. +039 - 0331 214511*

*www.chiaravalli.com*

