



### INTRODUCTION

Flexible torsion couplings, which are connecting devices between rotating shafts, are designed to ensure shock-free torque transmission and to compensate minor alignment deviations in operation between the shafts in industrial use.

The GE-T range of flexible couplings ensures this level of performance and also provides excellent quality thanks to the machining accuracy and the choice of materials.

The general level of reliability provided by the GE-T couplings results in a long life operation.



### GENERAL

The GE-T range of flexible couplings represents torsionally flexible mechanical couplings capable of transmitting a twisting moment proportional to the flexible yield of the intermediate component. The couplings must be capable of effectively absorbing possible torsional vibrations due to the load or self-induced, to attenuate impacts and torque peaks during the start-up phase and to compensate minor angular and parallel misalignments between the shafts, however ensuring an acceptable useful working life.

These features and more in general the performance required from the coupling depend almost exclusively on the quality intermediate component.

The choice of the material used to manufacture the coupling is therefore fundamental. The curve that expresses the flexible characteristic of the intermediate component must have a progressive trend (yielding at low torque values and remaining rigid at higher torque values) to ensure operation without jerks at start-up and with a limited torsional yield at steady state conditions.

It is essential for the intermediate component to have a certain flexible hysteresis, proportional to the required absorbing effect that ensures the coupling can efficiently absorb possible torsional oscillations.

Furthermore, the useful working life of the coupling depends on the flexible yield of the material comprising the intermediary component. The physical characteristics has described above are frequently in contrast with each other and compared with other basic mechanical and technological parameters. The performance of the intermediary component therefore cannot be adapted to the variety of operating conditions when only one type of material is used and therefore the materials adopted for the flexible ring gear must be differentiated.

A selected thermoplastic elastomer is selected to meet medium level needs in the basic execution. This refers to an elastomer with medium rigidity, characterised by an optimum internal dampening effect, resistant to ageing, to fatigue, to abrasion, as well as hydrolysis and to the principle chemical agents with special reference to oils and ozone. Operating temperatures lying between -40 °C and + 125 °C with brief peaks of up to 150 °C are permitted in the case of couplings in the base execution. Alternative mixes capable of meeting every practical need have been designed and are available on request for use in extremely demanding operating conditions, or for needs that exceed average requirements.

### OPERATING AND ASSEMBLY CONDITIONS

Operation of the flexible torsion couplings, such as the GE-T type or similar couplings is characterized by a proportional feature between the twisting torque and the torsion angle and by the ability to compensate limited angular and radial misalignments.

Key features of equal importance, but which are more difficult to interpret are represented by the absorbing factor and natural frequency or resonance.

To qualify its couplings, Chiaravalli Trasmissioni SpA declares permitted twisting torque values correlated to well defined torsion angle values, which has the limiting value of 5 ° C corresponding to the maximum torque value. This provides a valid guide for the progressive characteristic of the flexible curve. The maximum permitted values are shown in the case of the angular and radial misalignments, with the warning that these refer to extreme values that cannot be added together (only angular compensation or only radial compensation) and apply to standard operating conditions characterised by the following: operating torque not exceeding the nominal torque, a rotating speed of less than 1,450 r.p.m and coupling temperature not exceeding 40° C.

The maximum rotating speed expressed in r.p.m that corresponds to maximum peripheral speed of 30 m/sec. is indicated for each coupling of the GE-T range.

This speed can be achieved with a sufficient safety margin compared to the danger of failure due to centrifugal force stress thanks to the characteristics of the material used.

Class G 2.5 dynamic balancing in compliance with ISO 1940 is recommended despite the fact that the half-couplings are fully machined on both external surfaces, if the actual operating speed exceeds 2.800 r.p.m.

Pieces available with E-coating.

Scan the QR Code to gather more information regarding e-coating





**COUPLING SELECTION AND SIZING CRITERION**

Couplings are sized on the basis of the physical laws of mechanics and the resistance of the materials and also complies on the provisions established in the DIN 740 standards. the coupling is selected on the basis of the criterion, which establishes that the maximum permitted stress is never exceeded even in the most demanding operating conditions. It follows that the nominal torque declared for the coupling must be compared with a reference torque that takes into account the overloads due to the way the load is exerted and the operating conditions. The reference torque is obtained by multiplying the operating torque by a series of multiplying factors depending on the nature of the load or on the ambient temperature conditions.

**LOAD DUE TO NOMINAL TORQUE**

The permitted nominal coupling torque TKN must apply for any operating temperature value equal to or greater than the driven side operating torque TLN.

$$TKN = 9549 \frac{(PLn) [Nm]}{nLn}$$

The following condition must be satisfied, where St represents the temperature factor, to take into account overloads due to the operating temperature for the coupling.

$$TKn > TLN * St$$

**START - UP LOAD**

The drive motor delivers a drive torque during the start-up transient period which is a multiple of the nominal torque and depends on the way the masses are distributed. A similar situation occurs in the braking phase therefore, this two phases are characterised by torque impacts that have an intensivity which depends on the distribution of the masses on the drive side MA and on the driven side ML, as well as the frequency of the number of start – ups on which the start – up factor Sz depends. The static torques for the drive side and the driven side are expressed by the following relationships:

- drive side  $TS = TAS * MA * SA$

- driven side  $TS = TLS * ML * SL$

MA and ML are assumed to be equal to 1, to first approximation, and if the distribution of the masses is unknown. The SA factor can be assumed as being equal to the relationship between the start – up torque and the nominal torque in the case of drives based on an electric motor.

**LOAD CAUSED BY TORQUE IMPACTS**

The permitted nominal coupling torque TKN max must be equal to or greater than the start-up torque increased by the temperature factor and by St and by the start-up factor Sz for any operating temperature value.

$$TKn_{max} > TS * St * Sz$$

Consult the CHIARAVALLI Trasmissioni Technical Department for operating conditions that foresee periodic variation or torque inversions, as well as alternate torsional stresses.

**SYMBOLS**

- Tk n** = coupling maximum torque (Nm)
- Tk max** = coupling maximum torque (Nm)
- Tk w** = torque with coupling inversion (Nm)
- TLN** = driven side operating torque (Nm)
- TLs** = driven side static torque (Nm)
- TAs** = motor side static torque (Nm)
- Ts** = plant static torque (Nm)
- PLn** = driven side operating power (Nm)
- nLn** = driven side rotating speed (r.p.m)
- St** = temperature factor
- JA** = inertia moment drive site
- JL** = exit side
- SA** = motor side impact factor
- SL** = driven side impact factor
- Sz** = start-up factor

**MA** = control side mass factor  $\frac{JL}{JA + JL}$

**ML** = driven side mass factor  $\frac{JA}{JA + JL}$

**INDICATIVE VALUES FOR ADJUSTMENT FACTORS:**

Name	Symbol	Definition				
		St.	1	1,4	1,8	
Temperature factor	St.	C°	-30°	+40°	+80°	+120°
			+30°			
Start-up factor	Sz.	Number of start-ups per hour				
		Start-up/hr	100	200	400	800
		Sz.	1	1,2	1,4	1,6
Impact factor	SA/SL					SA/SL
		minor start-up impacts				1,5
		medium start-up impacts				1,8
		major start-up impacts				2,2

**SERVICE FACTORS:**

Load condition	Operating conditins	Type of Drive	
		Electric motor	Diesel engine
UNIFORM	Regular operation without impacts or overloads	1,25	1,50
LIGHT	Regular operations with minor and infrequent impacts and overloads	1,50	2,00
MEDIUM	Irregular operation with medium overloads for a short duration and frequent but moderate impacts	2,00	2,50
HEAVY	Markedly irregular operation with very frequent impacts and overloads and of major intensity	2,50	3,00

# CHIARAVALLI GROUP BRAND GIFLEX®

## AXIS MISALIGNMENTS COMPENSATED WITH COUPLING GE-T



### TECHNICAL DATA

Spider for GE-T	
Employment temperature	
- Black	-40° +140°
- Yellow	-40° +90°
- Red	-30° +90°
- Green	-30° +110°



BLACK SPIDER 92-94Sh A THERMOPLASTIC



YELLOW SPIDER 92-94Sh A POLYURETHAN



RED SPIDER 96-98 Sh A POLYURETHAN



GREEN SPIDER 64 Sh D POLYURETHAN

### TECHNICAL DATA

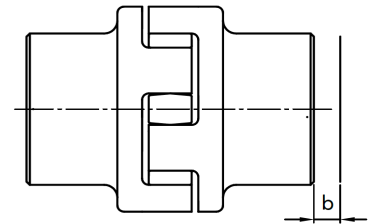
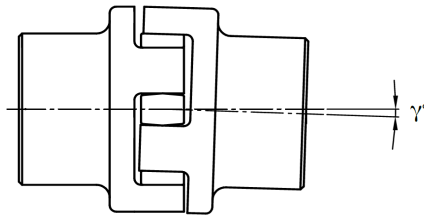
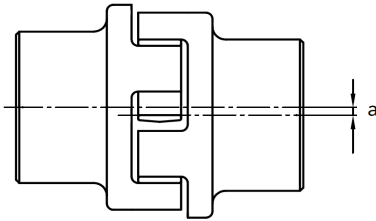

### TECHNICAL DATA

SPIDER TYPE	MAX R.p.M.	SPIDER	COLOR	TORSION ANGLE		TORQUES (Nm)			Torsional rigidity (NMrad)				displacement		
				Tk n	tk MAX	Norm.	Max	with invers.	1.0	0.75	0.5	0.25	axial	radial	angular
GE-T 19-24	1400	92/94 Sh a	BLACK	3°	5°	10	20	2,6	1280	1050	800	470	1,2	0,2	1,2°
		92/94 Sh a	YELLOW			17	34	4,4	2920	2390	1810	1070			
		96/98 Sh a	RED			21	42	5,5	5350	4390	3320	1970			
		64 Sh D	GREEN			35	70	9	4860	3980	3010	1790			
GE-T 24-32	10600	92/94 Sh a	BLACK			60	120	16	9930	8140	6160	3650	1,4	0,2	0,9°
		92/94 Sh a	YELLOW			75	150	19,5	15110	12390	9370	5950			
		96/98 Sh a	RED			95	190	25	10900	8940	6760	4010			
		64 Sh D	GREEN			160	320	42	26770	21950	16600	9840			
GE-T 28-38	8500	92/94 Sh a	BLACK			200	400	52	27520	22570	17060	10120	1,5	0,25	0,9°
		92/94 Sh a	YELLOW			190	380	49	21050	17260	13050	7740			
		96/98 Sh a	RED			325	650	85	48570	39830	30110	17850			
		64 Sh D	GREEN			405	810	105	70150	57520	43490	25780			
GE-T 38-45	7100	92/94 Sh a	BLACK			265	530	69	23740	19470	14720	8730	1,8	0,28	1,0°
		92/94 Sh a	YELLOW			450	900	117	54500	44690	33790	20030			
		96/98 Sh a	RED			560	1120	145	79860	65490	49520	29350			
		64 Sh D	GREEN			310	620	81	36700	30090	22750	13490			
GE-T 42-55	6000	92/94 Sh a	BLACK	525	1050	137	65290	53540	40480	24000	2,0	0,32	1,0°		
		92/94 Sh a	YELLOW	655	1310	170	95510	78320	59220	35100					
		96/98 Sh a	RED	410	820	105	50720	41590	31450	18640					
		64 Sh D	GREEN	625	1250	163	94970	77880	58880	34900					
GE-T 48-60	5600	92/94 Sh a	BLACK	825	1650	215	107920	88500	66910	39660	2,1	0,36	1,1°		
		92/94 Sh a	YELLOW	625	1250	163	97130	79650	60220	35700					
		96/98 Sh a	RED	940	1880	166	129510	106200	80300	47600					
		64 Sh D	GREEN	1175	2350	305	151090	123900	93680	55530					
GE-T 55-70	4750	92/94 Sh a	BLACK	1250	2500	330	113320	92920	70260	41650	2,2	0,38	1,1°		
		92/94 Sh a	YELLOW	1910	3850	490	197500	161950	122450	72580					
		96/98 Sh a	RED	2410	4820	624	248220	203540	153900	91220					
		64 Sh D	GREEN	2400	4800	624	190090	155870	117860	69860					
GE-T 65-75	4250	92/94 Sh a	BLACK	3600	7200	936	312200	256000	193560	114730	2,6	0,42	1,2°		
		92/94 Sh a	YELLOW	4500	9000	1170	674520	553110	418200	247890					
		96/98 Sh a	RED												
		64 Sh D	GREEN												
GE-T 75-90	3550	92/94 Sh a	BLACK								3,0	0,48	1,2°		
		92/94 Sh a	YELLOW												
		96/98 Sh a	RED												
		64 Sh D	GREEN												
GE-T 90-100	2800	92/94 Sh a	BLACK								3,4	0,5	1,2°		
		92/94 Sh a	YELLOW												
		96/98 Sh a	RED												
		64 Sh D	GREEN												

with radial speed more than v=30m/s dynamic balancing is needed

EXAMPLE SPIDER CODE: 0200 24 14 → 010 BLACK  
 012 YELLOW  
 013 GREEN  
 014 RED

↓ TYPE  
 ↓ SPIDER GE-T



# CHIARAVALLI GROUP BRAND GIFLEX®

## GE-T SERIES WITH ELASTIC SPIDER - ACCURATE DESIGN

### TECHNICAL DATA

CAST IRON GG 25

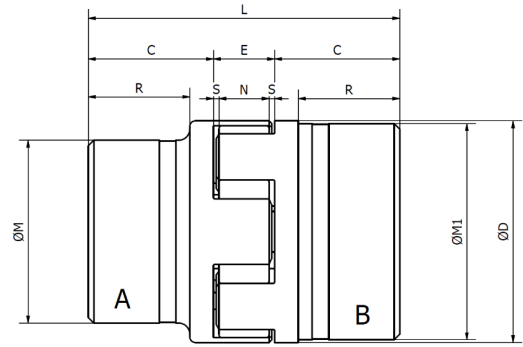
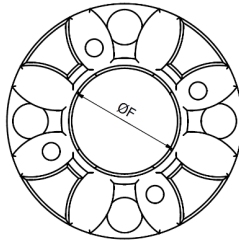

COUPLING TYPE	Ø BORE		Ø MAX BORE ALLOWED		DIMENSIONS											
					A-B										BL	
					A	B/BL	A max	B/BL max	C	ØD	E	ØG	ØM	ØM1	N	R
GE-T 19A-24B*	-	-	19	24	25	40	16	18	30	40	12	19	2	66	37	31
GE-T 24A-32B	-	-	24	32	30	55	18	27	40	55	14	24	2	78	50	44
GE-T 28A-38B	-	-	28	38	35	65	20	30	48	65	15	27,5	2,5	90	60	52,5
GE-T 38A-45B	-	-	38	45	45	80	24	38	66	78	18	36,5	3	114	70	61,5
GE-T 42A-55B	-	-	42	55	50	95	26	46	75	94	20	40	3	126	75	65
GE-T 48A-60B	-	-	48	60	56	105	28	51	85	104	21	45	3,5	140	80	69
GE-T 55A-70B	-	-	55	70	65	120	30	60	98	118	22	52	4	160	90	88
GE-T 65A-75B	-	-	65	75	75	135	35	68	115	134	26	61	4,5	185	100	86
GE-T 75A-90B	-	-	75	90	85	160	40	80	135	158	30	69	5	210	110	97
GE-T 90A-100B	38	38	90	100	100	200	45	100	160	180	34	81	5,5	245	125	106

COUPLING TYPE	WEIGHT Kg				J Kg cm <sup>2</sup> mozzi
	SPIDER elastico	HUB A	HUB B	HUB BL	
GE-T 19A-24B*	0,004	0,18	0,25		0,8
GE-T 24A-32B	0,014	0,36	0,55		3
GE-T 28A-38B	0,025	0,6	0,85		7
GE-T 38A-45B	0,042	1,35	1,65		20
GE-T 42A-55B	0,066	2	2,3		50
GE-T 48A-60B	0,088	2,75	3,1		80
GE-T 55A-70B	0,116	4,2	4,5		160
GE-T 65A-75B	0,172	6,5	6,8		310
GE-T 75A-90B	0,325	10	10,8		680
GE-T 90A-100B	0,44	14	15,8		1590

EXAMPLE HUB CODE:

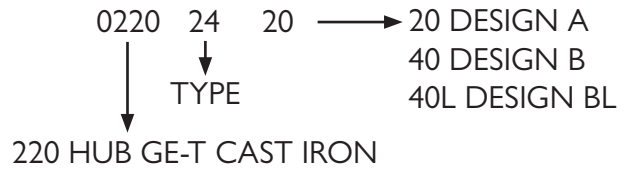

J Inertia moment hub A+B with max bore allowed

MAT. C45 EN 10083  
 MAT CAST IRON G20/25 EN 1561

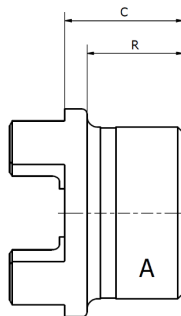

DESIGN A

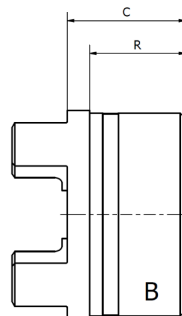

DESIGN B

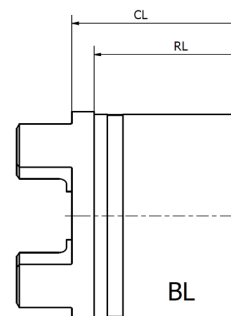

DESIGN BL

**NEW**



**ALUMINIUM ALLOY**

**INTERPRETATION CODES**

**EXAMPLE**

**GE-T 19A-24B/AI = HUB A + HUB B**

**GE-T 19A-19A/AI = 2 hubs A**

**GE-T 24B-24B/AI = 2 hubs B**

The characteristic size of the coupling is defined by the maximum diameter bore.

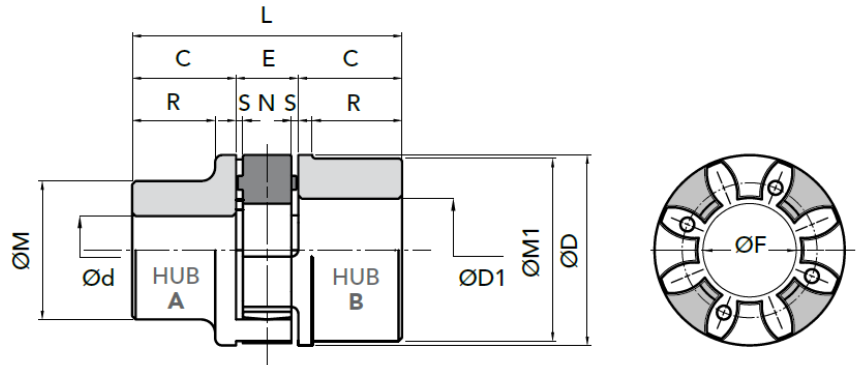

**PART NUMBERS**

COUPLING TYPE	PART NUMBER	PART NUMBER
	HUB A	HUB B
GE-T 19A-24B/AI	02301920	02301940
GE-T 24A-32B/AI	02302420	02302440
GE-T 28A-38B/AI	02302820	02302840
GE-T 38A-45B/AI	02303820	02303840

**MEASUREMENTS - WEIGHTS**

COUPLING TYPE	Ø pilot bore		Ø finished bore		measurement in mm normal range										Weight Kg			J Kg cm <sup>2</sup> hubs A+B
	A	B	Ød max	ØD1 max	C	ØD	E	ØF	ØM	ØM1	N	R	S	L	spider	HUB A	HUB B	
																A	B	
GE-T 19A-24B/AI	6	10	19	24	25	40	16	18	30	40	12	19	2	66	0,005	0,07	0,08	0,4
GE-T 24A-32B/AI	8	14	24	32	30	55	18	27	40	55	14	24	2	78	0,014	0,13	0,18	1
GE-T 28A-38B/AI	10	16	28	38	35	65	20	30	48	65	15	27,5	2,5	90	0,025	0,22	0,3	3
GE-T 38A-45B/AI	12	20	38	45	45	80	24	38	66	78	18	36,5	3	114	0,042	0,48	0,55	8

J inertia torque HUB A+B with bore max Ø



# CHIARAVALLI GROUP BRAND GIFLEX®

## GE-T SERIES WITH ELASTIC SPIDER - ACCURATE DESIGN

### CAST-IRON GG25

with **TAPER BUSH® LOCK**

#### INTERPRETATION CODES

#### EXAMPLE

**GE-T 28I-38E** = HUB I + HUB E

**GE-T 28E-38I** = HUB E + HUB I

**GE-T 28I-28I** = 2 hubs I

**GE-T 38E-38E** = 2 hubs E

Insertion bush:

HUB **I** with internal assembled bush

HUB **E** with external assembled bush

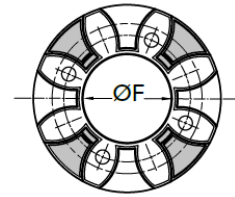
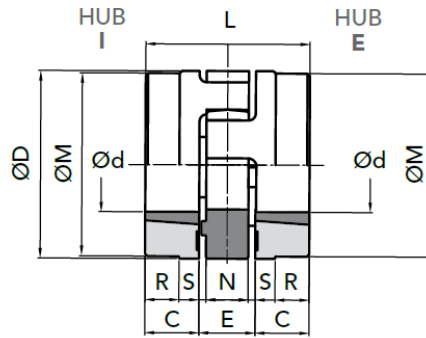

### PART NUMBERS FOR COMPLETE COUPLINGS

COUPLING TYPE	PART NUMBER	PART NUMBER
	HUB I	HUB E
GE-T 28-38 TL	03202841	03202840
GE-T 38-45 TL	03203841	03203840
GE-T 42-55 TL	03204241	03204240
GE-T 48-60 TL	03204841	03204840
GE-T 55-70 TL	03205541	03205540
GE-T 75-90 TL	03207541	03207540

### MEASUREMENTS - WEIGHTS

COUPLING TYPE	Ø pilot bore	finished bore		measurement in mm normal range									Weight Kg		J Kg cm <sup>2</sup> hubs
		Ød max	ØD1 max	C	ØD	E	ØF	ØM	N	S	L	R	spider	HUB bore max	
GE-T 28-38 TL	1108	14	25	23	65	20	30	65	15	2,5	66	-	0,025	0,50	7
GE-T 38-45 TL	1108	14	25	23	80	24	38	78	18	3	70	15	0,042	0,88	26
GE-T 42-55 TL	1610	14	42	26	95	26	46	94	20	3	78	16	0,066	1,40	36
GE-T 48-60 TL	1615	19	40	39	105	28	51	104	21	3,5	106	28	0,088	2,33	78
GE-T 55-70 TL	2012	19	50	33	120	30	60	118	22	4	96	20	0,116	2,42	120
GE-T 75-90 TL	2517	19	65	57	160	40	80	158	30	5	154	41	0,325	6,80	630

# CHIARAVALLI GROUP BRAND GIFLEX®

## GE-T SG SERIES BACKLASH-FREE TORSIONAL COUPLING



### INTRODUCTION

The aluminium flexible couplings GE-T SG are made of three pre-tensioned elements in backlash-free execution. They are meant for the coupling mounting and they are designed to fit low torque working units and industrial processing, where they must satisfy certain requirements.

Thanks to their limited dimensions and their easy mounting, they can operate in little space and any project can take big advantages of it.

### FEATURES

The buckle tightening guarantees a quick and sure fixing without extension between shaft and hub. It is however important to keep the screw tightening torque (MS) shown in the table. Besides testing the size of the coupling given in the table, it is suggested to test the maximum torque of buckle to diameter (F).

The elastomeric element, that has a star shape, is set into the hubs' hollow seats with a light pre-tensioning, ensuring the needed transmission torque backlash-free execution.

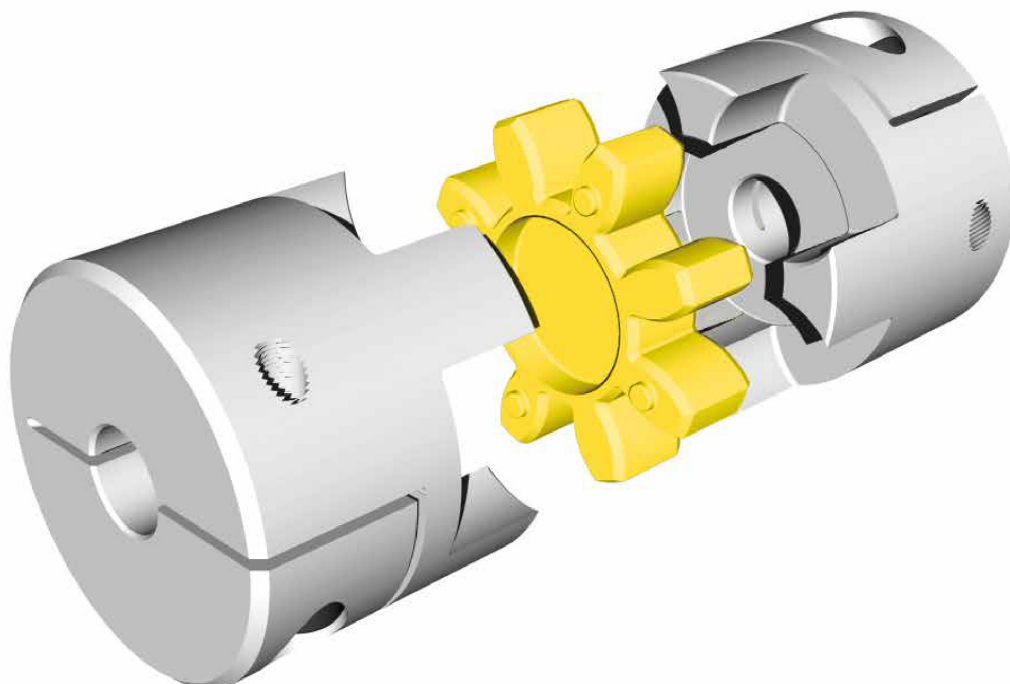
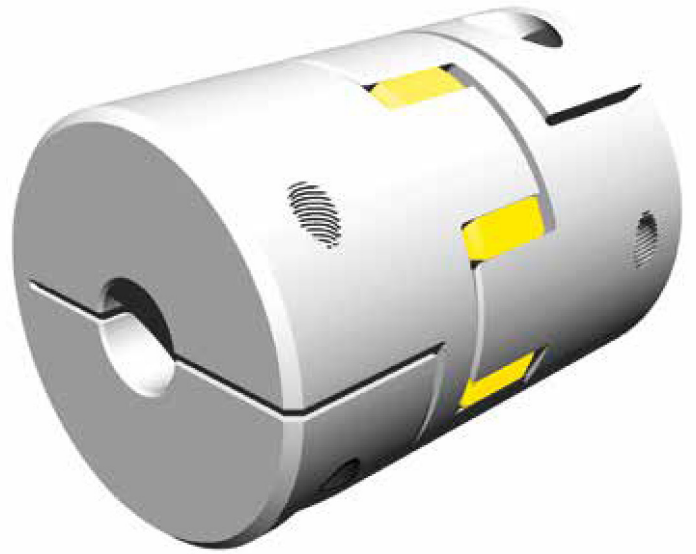

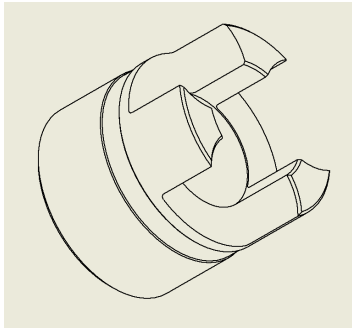

**DESIGN A**

Solid hub size 9 and 14 for 4-spikes elastomer, size 19 for 6-spikes elastomer

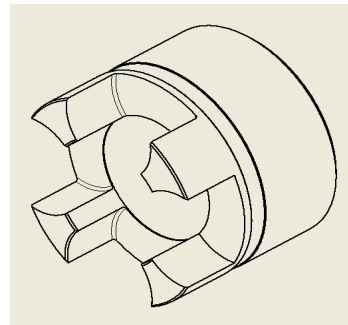

**DESIGN B**

Solid hub from size 24 to 38 for 8-spikes elastomer

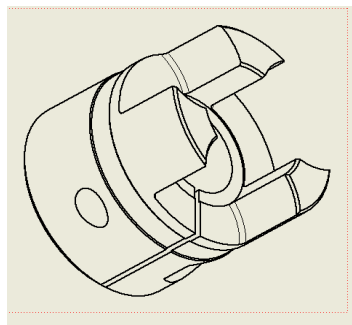

**DESIGN C**

With single-cut clamp from size 9 to size 19, torques suitable according to hole-diameter.  
Also available with the compact version from size 9 to size 38

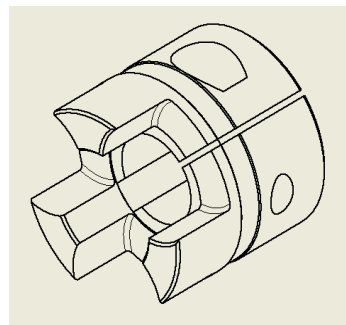

**DESIGN CK**

With single-cut clamp and keyway acc.to DIN 6885 - JS9 , from size 14 to size 19. Also available with the compact version from size 9 to size 38

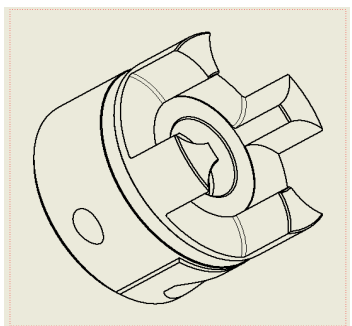

**DESIGN D**

With double-cut clamp from size 24 to size 38, torques suitable according to hole-diameter

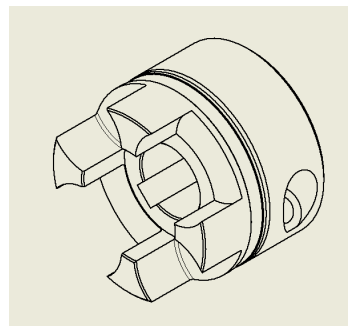

**DESIGN DK**

With double-cut clamp and keyway acc.to DIN 6885 - JS9 , from size 24 to size 38

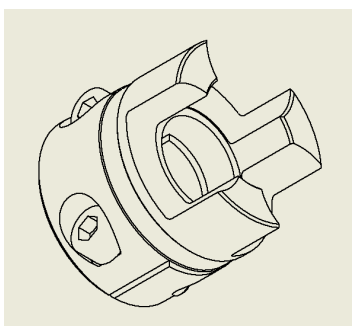

**DESIGN H**

With 2x screws fixing clamp for radial mounting, torques suitable according to hole-diameter. Available from size 14 to size 42

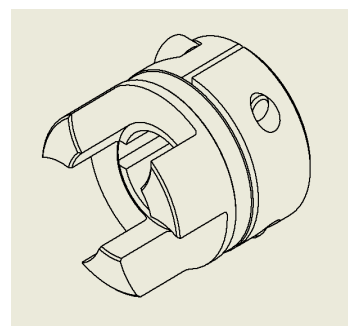

**DESIGN HK**

With 2x Screws fixing clamp for radial mounting and keyway acc.to DIN 6885-JS9. Available from size 14 to size 42



# CHIARAVALLI GROUP BRAND GIFLEX®

## GE-T SERIES WITH ELASTIC ELEMENT – TRANSFERABLE PAIRS



BLUE 80 Sh A  
POLYURETHAN



YELLOW 92/94 Sh A  
POLYURETHAN

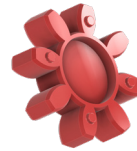

RED 96/98 Sh A  
POLYURETHAN

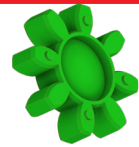

GREEN 64 Sh D  
POLYURETHAN

NEW

### TECHNICAL DATA

COUPLING TYPE	HARDNESS WITH SPIDER	MAX speed for type				Nm		Stiffness			Max inertia moment Kgm <sup>2</sup> x 10 <sup>-6</sup>
		Design C	Design D	Design H	max	Tk n couple	Tk max couple	tors. static Nm/rad	tors. dynamic Nm/rad	radial Nm	
GE-T 9 SG	80 Sh A	19000			28000	1,8	3,6	17,02	52	125	0,57
	92/94 Sh A					3	6	31,5	95	262	
	96/98 Sh A					5	10	51,5	150	518	
GE-T 14 SG	80 Sh A	12700		12700	19000	4	8	60,2	180	153	3,25
	92/94 Sh A					7,5	15	114,6	344	336	
	96/98 Sh A					12,5	25	172	513	604	
	64 Sh D					16	32	238	702	856	
GE-T 19-24 SG	80 Sh A	9550		9550	14000	4,9	9,8	343,8	1030	740	21,9
	92/94 Sh A					10	20	573	1720	1260	
	96/98 Sh A					17	34	859	2580	2210	
	64 Sh D					21	42	2450	3820	2970	
GE-T 24-28 SG	80 Sh A		6950	6950	10600	17	34	850	1385	840	58,3
	92/94 Sh A					35	70	2280	4296	1900	
	96/98 Sh A					60	120	3700	8125	2940	
	64 Sh D					75	150	5000	11000	3700	
GE-T 28-38 SG	80 Sh A		5850	5850	8500	46	92	1360	2345	990	216,8
	92/94 Sh A					95	190	3820	7260	2100	
	96/98 Sh A					160	320	4190	10315	3680	
	64 Sh D					200	400	10010	20035	4400	
GE-T 38-45 SG	80 Sh A		4750	4750	7100	95	190	3000	6100	1400	445,2
	92/94 Sh A					190	380	4589	13752	2900	
	96/98 Sh A					325	650	7160	21485	5040	
	64 Sh D					405	810	25600	40250	6445	
GE-T 42 SG	80 Sh A		4000	4000	6000	46	92			990	2802
	92/94 Sh A					95	190	2292	6879	2100	
	96/98 Sh A					160	320	3438	10315	3680	
	64 Sh D									4400	

with radial speed more than v=30m/s dynamic balancing is needed

Axial Displacement

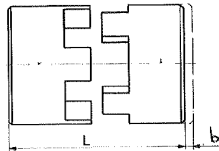

Radial Displacement

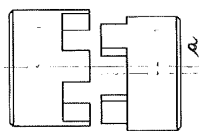

Angular Displacement

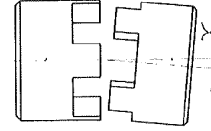

COUPLING TYPE	Displacement			
	spider GE-T SG	AXIAL b (mm)	RADIAL a (mm)	ANGULAR U(degree)
GE-T 9 SG	80 Sh A	+0,9	0,19	1,1°
	92/94 Sh A		0,13	1,0°
	96/98 Sh A	-0,9	0,08	0,9°
	64 Sh D		0,05	0,8°
GE-T 14 SG	80 Sh A	+1,0	0,21	1,1°
	92/94 Sh A		0,15	1,0°
	96/98 Sh A	-0,5	0,09	0,9°
	64 Sh D		0,08	0,8°
GE-T 19-24 SG	80 Sh A	+1,2	0,15	1,1°
	92/94 Sh A		0,10	1,0°
	96/98 Sh A	-0,5	0,08	0,9°
	64 Sh D		0,04	0,8°
GE-T 24-28 SG	80 Sh A	+1,4	0,14	1,0°
	92/94 Sh A		0,10	0,9°
	96/98 Sh A	-0,5	0,07	0,8°
	64 Sh D		0,04	0,7°
GE-T 28-38 SG	80 Sh A	+1,5	0,15	1,0°
	92/94 Sh A		0,11	0,9°
	96/98 Sh A	-0,5	0,08	0,8°
	64 Sh D		0,05	0,7°
GE-T 38-45 SG	80 Sh A	+1,8	0,17	1,0°
	92/94 Sh A		0,12	0,9°
	96/98 Sh A	-0,7	0,09	0,8°
	64 Sh D		0,06	0,7°
GE-T 42 SG	80 Sh A	+2,0	0,19	1,0°
	92/94 Sh A		0,14	0,9°
	96/98 Sh A	-1,0	0,10	0,8°
	64 Sh D		0,07	0,7°

EXAMPLE SPIDER CODE:

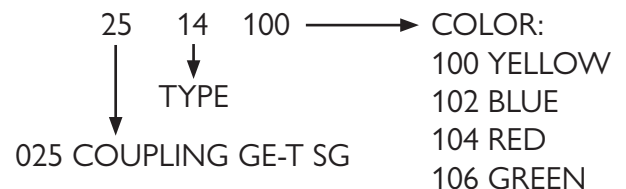



# CHIARAVALLI GROUP BRAND GIFLEX®

## GE-T SG SERIES BACKLASH-FREE TORSIONAL COUPLING

### TECHNICAL DATA

HUB DESIGN A AND B - SOLID HUB  
MAT ALUMINIUM

With spider  
4 pointed

**GE-T 09 SG**  
**GE-T 14 SG**

6 pointed  
8 pointed

**GE-T 19-24 SG**  
**GE-T 24-28 SG**  
**GE-T 28-38 SG**  
**GE-T 38-45 SG**

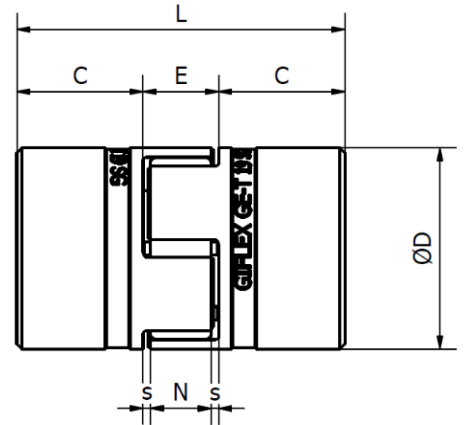
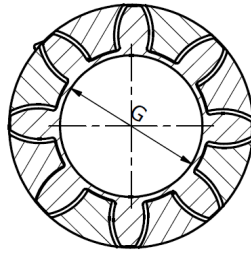

### DIMENSIONS

Coupling Type	achievable minimum bore Ø	achievable maximum bore Ø	Ø D	Ø G	L	C	E	N	S	Design
GE-T 09 SG	4	9	20	7,2	30	10	10	8	1	A
GE-T 14 SG	4	14	30	10,5	35	11	13	10	1,5	A
GE-T 19-24 SG	10	20	40	18	66	25	16	12	2	A
GE-T 24-28 SG	15	28	55	27	78	30	18	14	2	B
GE-T 28-38 SG	19	35	65	30	90	35	20	15	2,5	B
GE-T 38-45 SG	20	45	80	38	114	45	24	18	3	B

MAT: Aluminium 6082-T6 EN 573

EXAMPLE HUB CODE:

025 14 200 → 200 SOLID HUB  
 ↓ TYPE  
 025 COUPLING GE-T SG

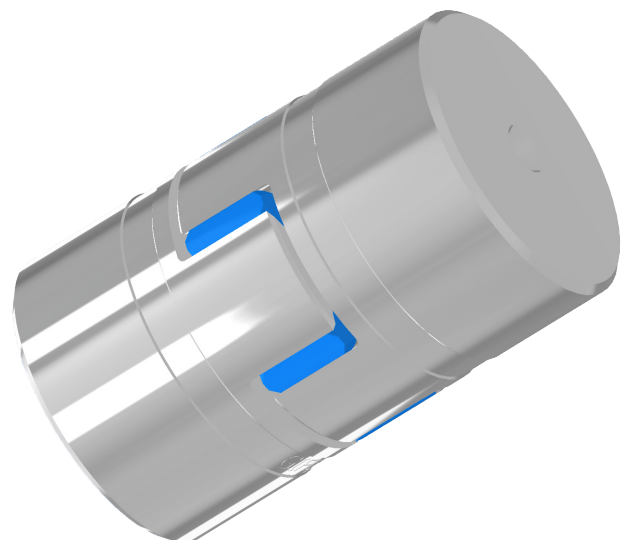

# CHIARAVALLI GROUP BRAND GIFLEX®

## GE-T SG SERIES BACKLASH-FREE TORSIONAL COUPLING



### TECHNICAL DATA

**HUB DESIGN C**  
WITH SINGLE CUT

With spider  
4 pointed

**GE-T 09 SG**  
**GE-T 14 SG**

6 pointed

**GE-T 19-24 SG**

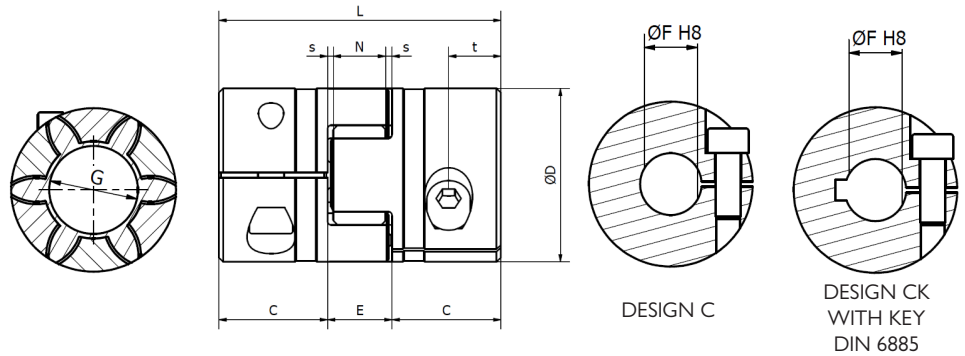

DIMENSIONS											
COUPLING TYPE	ØF H8 - friction torque for design C	Ø D	Ø G	L	C	E	N	s	f	Ms screw (Nm) clamping torque	t
GE-T 09 SG	5 - 6 - 8 - 10	20	7,2	30	10	10	8	1	M2,5	0,75	5
FRICITION TORQUE Nm	1,55 - 1,63 - 1,79 - 1,94										
GE-T 14 SG	5 - 6 - 8 - 10 - 12 - 14 - 15 - 16	30	10,5	35	11	13	10	1,5	M3	1,4	5
FRICITION TORQUE Nm	3,32 - 3,43 - 3,67 - 3,91 - 4,14 - 4,38 - 4,5 - 4,6										
GE-T 19-24 SG	8 - 10 - 12 - 14 - 15 - 16 - 18 - 19 - 20	40	18	66	25	16	12	2	M6	11	12
FRICITION TORQUE Nm	18 - 19 - 20 - 21 - 21,5 - 22 - 22,5 - 23 - 24										

EXAMPLE HUB CODE:

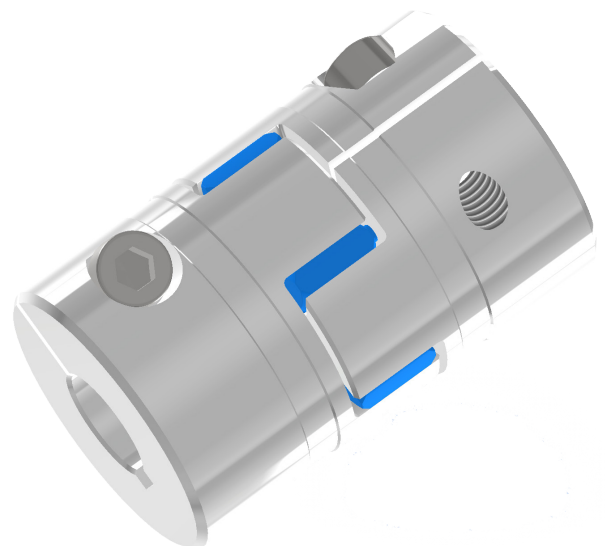
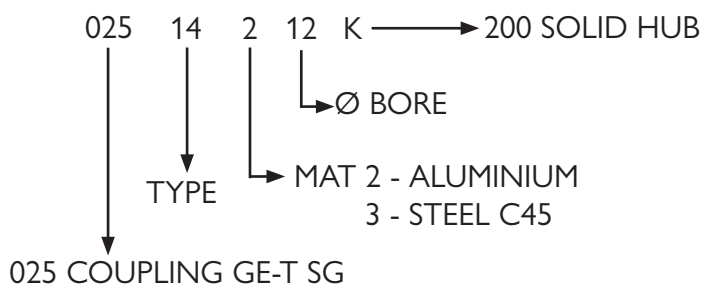

MAT: ALUMINIUM 6082 - T6 EN 573

MAT: STEEL C45 EN 10083



# CHIARAVALLI GROUP BRAND GIFLEX®

## GE-T SG SERIES BACKLASH-FREE TORSIONAL COUPLING

### TECHNICAL DATA

#### HUB DESIGN D WITH DOUBLE CUT

with spider  
8 pointed

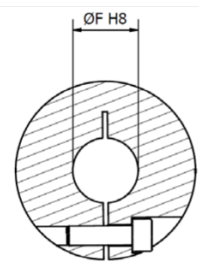
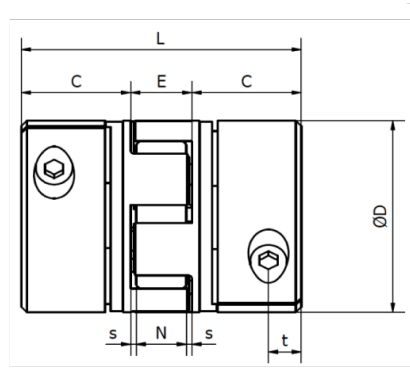
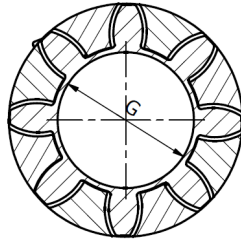

Design D

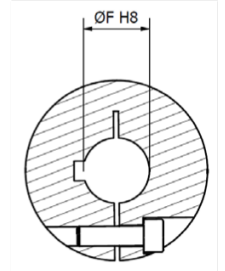

Design DK  
with key  
DIN 6885

### DIMENSIONS

COUPLING TYPE	ØF H8 - friction torque for design D	Ø D	Ø G	L	C	E	N	s	f	Ms screw (Nm) clamping torque	t
GE-T 24-28 SG	12 14 15 16 18 19 20 22 24 25 28	55	27	78	30	18	14	2	M6	11	14
FRICITION TORQUE Nm	25 - 26 - 27 - 27,5 - 28 - 28,5 - 29 - 30 - 31 - 32 - 33										
GE-T 28-38 SG	18 19 20 22 24 25 28 30 32 35	65	30	90	35	20	15	2,5	M8	25	15
FRICITION TORQUE Nm	60 - 61 - 62 - 63 - 65 - 66 - 69 - 71 - 73 - 75										
GE-T 38-45 SG	18 19 20 22 24 25 28 30 32 35 38 40	80	38	114	45	24	18	3	M8	25	20
FRICITION TORQUE Nm	69 - 70 - 71 - 73 - 74 - 78 - 78 - 80 - 81 - 84 - 87 - 88										

#### EXAMPLE HUB CODE:

025 24 2 20 K → WITH KEYWAY  
 ↓  
 Ø BORE  
 ↓  
 MAT 2 - ALUMINIUM  
 3 - STEEL C45  
 ↓  
 TYPE  
 ↓  
 025 COUPLING GE-T SG

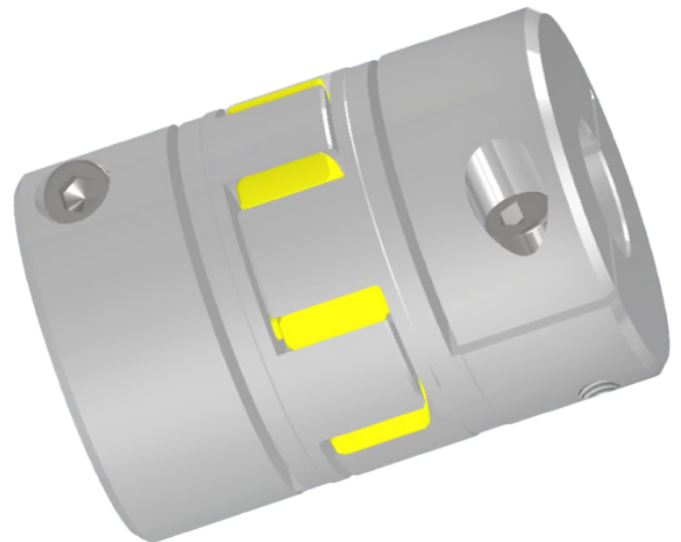

MAT: ALUMINIUM 6082 - T6 EN 573

MAT: STEEL C45 EN 10083

# CHIARAVALLI GROUP BRAND GIFLEX®

## GE-T SG SERIES BACKLASH-FREE TORSIONAL COUPLING



### TECHNICAL DATA

#### HUB EXECUTION C COMPACT VERSION WITH SINGLE CUT

MAT ALUMINIUM

With spider  
4 pointed

**GE-T 09 SG**  
**GE-T 14 SG**

6 pointed  
8 pointed

**GE-T 19-24 SG**  
**GE-T 24-28 SG**  
**GE-T 28-38 SG**  
**GE-T 38-45 SG**

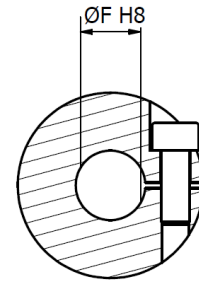
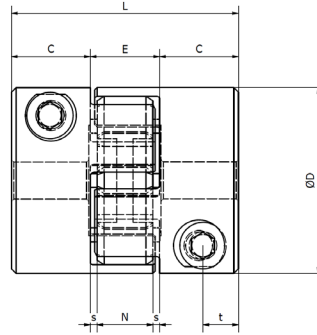
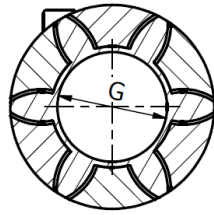

Design C

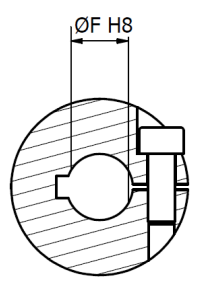

Design CK  
with key  
DIN 6885

### DIMENSIONS

COUPLING TYPE	ØF H8 - friction torque Nm for design C	Ø D	Ø G	L	C	E	N	S	SCREW	Ms screw (Nm) clamping torque	t
GE-T 09 SG C	5 - 6 - 8 - 10	20	7,2	24	7	10	8	1	M2,5	0,75	3,5
FRICITION TORQUE Nm	2 2.1 2.3 2.5										
GE-T 14 SG C	5 - 6 - 8 - 10 - 12 - 14 - 15 - 16	30	10,5	32	10,0	13	10	1,5	M4	3,1	5
FRICITION TORQUE Nm	7.1 7.4 8 8.5 9.1 10.2 10.5 11										
GE-T 19-24 SG C	8 - 10 - 12 - 14 - 15 - 16 - 18 - 19 - 20	40	18	50	17	16	12	2	M6	11	8,5
FRICITION TORQUE Nm	24.3 25.7 27 28.4 29 29.7 33.1 31.7 32,4										
GE-T 24-28 SG C	12 - 14 - 15 - 16 - 18 - 19 - 20 - 22 - 24 - 25 - 28	55	27	54	18	18	14	2	M6	11	9
FRICITION TORQUE Nm	36 37 38 39 40 41 41 42 44 44 46										
GE-T 28-38 SG C	18 - 19 - 20 - 22 - 24 - 25 - 28 - 30 - 32 - 35	65	30	62	21	20	15	2,5	M8	25	10,5
FRICITION TORQUE Nm	83 84 85 88 90 91 95 98 100 104										
GE-T 38-45 SG C	18 - 19 - 20 - 22 - 24 - 25 - 28 - 30 - 32 - 35 - 38 - 40	80	38	76	26	24	18	3	M10	45	13
FRICITION TORQUE Nm	105 108 112 120 125 129 135 143 150 160 172 181										

#### EXAMPLE HUB CODE:

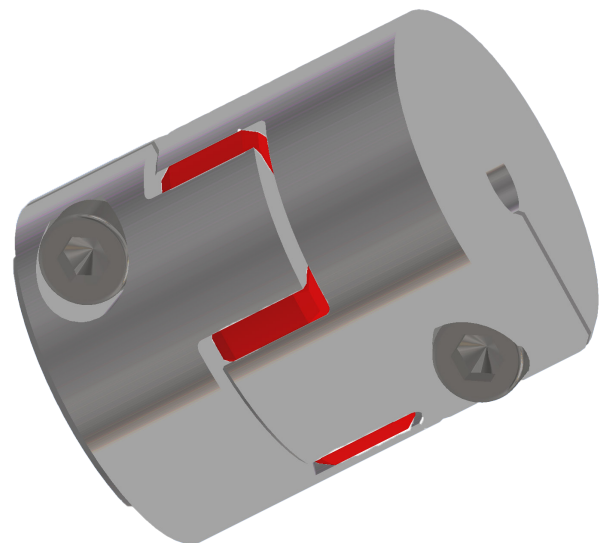
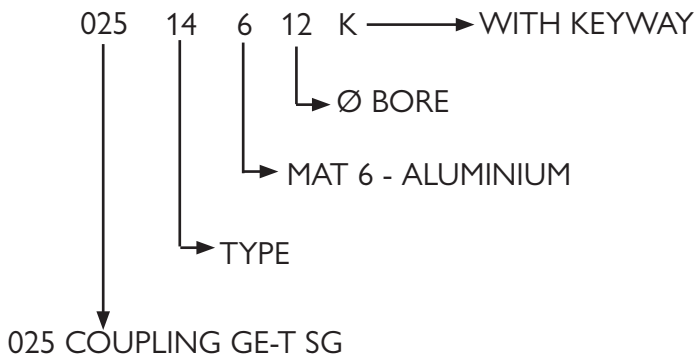

MAT: ALUMINIUM 6082 - T6 EN 573

MAT: ■ UPON REQUEST



# CHIARAVALLI GROUP BRAND GIFLEX®

## GE-T SG SERIES BACKLASH-FREE TORSIONAL COUPLING

### TECHNICAL DATA

#### HUB DESIGN H WITH HALFSHELL CLAMP

With spider  
4 pointed  
6 pointed  
8 pointed

**GE-T 14 SG**  
**GE-T 19-24 SG**  
**GE-T 24-28 SG**  
**GE-T 28-38 SG**  
**GE-T 38-45 SG**  
**GE-T 42-55 SG**

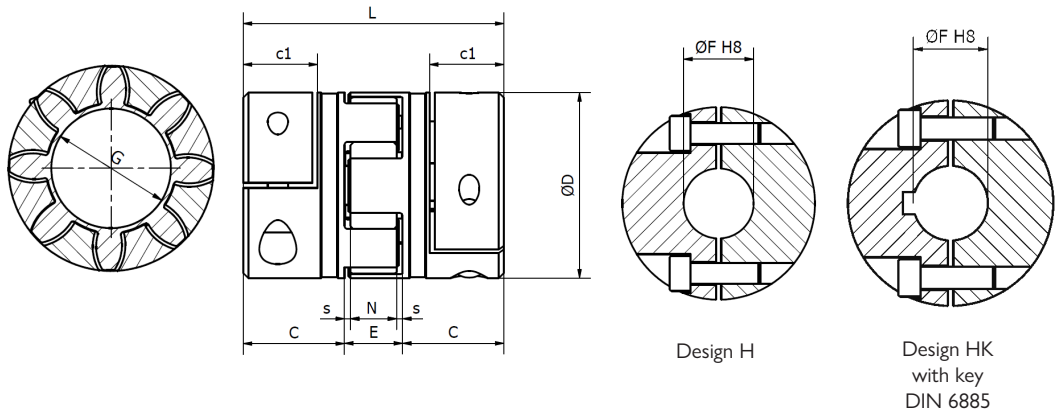

DIMENSIONS												
COUPLING TYPE	ØF H8 - friction torque Nm for design H	D	G	L	C	c1	E	N	s	SCREW	Ms screw (Nm) clamping torque	
GE-T 14SG	5 - 6 - 8 - 10 - 12 - 14 - 15 - 16	30	10,5	50	18	13,3	13	10	1,5	M4	5	
FRICITION TORQUE Nm	8 8.3 8.9 9.5 10.1 10.7 11 11,3											
GE-T 19-24SG	8 - 10 - 12 - 14 - 15 - 16 - 18 - 19 - 20	40	18	66	25	17,5	16	12	2	M6	10	
FRICITION TORQUE Nm	17 21 24 30 32 34 38 40 42											
GE-T 24-28SG	12 - 14 - 15 - 16 - 18 - 19 - 20 - 22 - 24 - 25 - 28	55	27	78	30	20,5	18	14	2	M6	10	
FRICITION TORQUE Nm	28 30 32 34 38 40 42 47 51 53 59											
GE-T 28-38SG	18 - 19 - 20 - 22 - 24 - 25 - 28 - 30 - 32 - 35	65	30	90	35	25	20	15	2,5	M8	25	
FRICITION TORQUE Nm	70 74 78 88 93 97 109 117 124 136											
GE-T 38-45SG	18 - 19 - 20 - 22 - 24 - 25 - 28 - 30 - 32 - 35 - 38 - 40	80	38	114	45	33	24	18	3	M8	25	
FRICITION TORQUE Nm	70 74 78 88 93 97 109 117 124 136 148 156											
GE-T 42-55SG	22 - 24 - 25 - 28 - 30 - 32 - 35 - 38 - 40 - 42 - 45 - 48 - 50	95	46	126	50	39	26	20	3	M10	45	
FRICITION TORQUE Nm	136 149 155 174 188 198 217 235 248 260 279 297 310											

#### EXAMPLE HUB CODE:

025 24 2 20 K → WITH KEYWAY  
 ↓  
 Ø BORE  
 ↓  
 MAT 2 - ALUMINIUM  
 3 - STEEL C45  
 ↓  
 TYPE  
 ↓  
 025 COUPLING GE-T SG

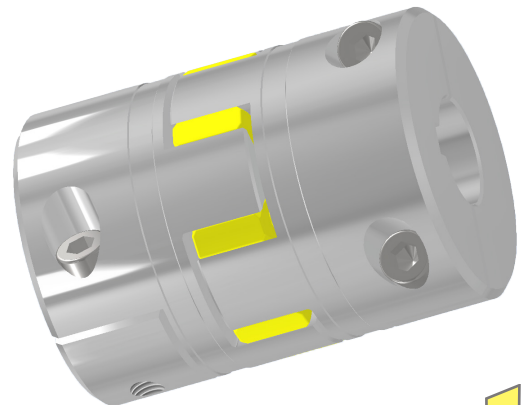
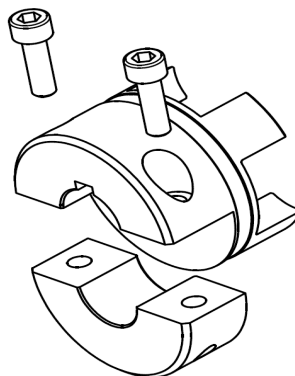

MAT: ALUMINIUM 6082 - T6 EN 573  
 MAT: STEEL C45 10083  
 MAT: ■ UPON REQUEST

# NEW



**NEW**

**TECHNICAL DATA**

**DESIGN B**  
One piece

**DESIGN C**  
Two pieces

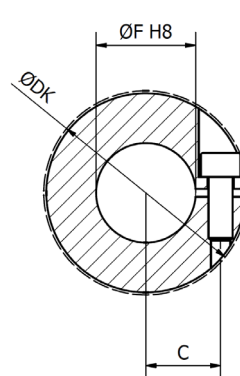
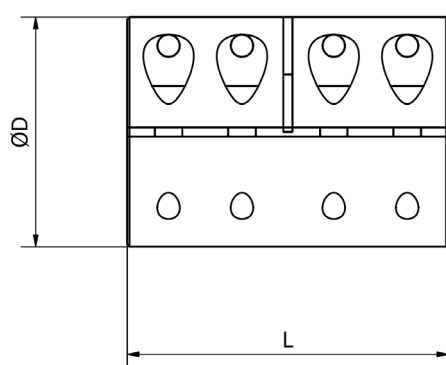

Design B

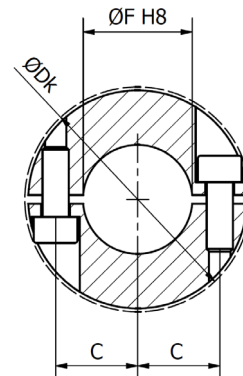

Design C

COUPLING TYPE	DIMENSIONS				
	Ø D	Ø DK	Ø F H8	L	C
JR001	32	33	10	45	10,5
JR002	40	-	15	50	13,5
JR003	45	47	20	65	16,25
JR004	50	52	25	70	18,75
JR005	55	57	30	75	21,25
JR006	65	70	35	85	25
JR007	70	74	40	90	27,5
JR008	80	83	45	100	31,25
JR009	90	95	50	110	35

MAT: STEEL C45 EN 10083

CH CODE	
DESIGN B	DESIGN C
RJ001B	RJ001C
RJ002B	RJ002C
RJ003B	RJ003C
RJ004B	RJ004C
RJ005B	RJ005C
RJ006B	RJ006C
RJ007B	RJ007C
RJ008B	RJ008C
RJ009B	RJ009C

COUPLING TYPE	TECHNICAL DATA						
	WEIGHT	FRICTION TORQUE Nm		MAX SPEED	SCREW 12.9		
	Kg	DESIGN B	DESIGN C	RPM	DESIGN B	DESIGN C	TIGHTENING TORQUE
RJ001	0,25	65	50	5500	n°4 x M4	n°8 x M4	4,9
RJ002	0,42	140	125	4200	n°4 x M5	n°8 x M5	9,7
RJ003	0,65	250	230	3800	n°4 x M6	n°8 x M6	17
RJ004	0,87	295	285	3500	n°4 x M6	n°8 x M6	17
RJ005	1,11	350	345	3200	n°4 x M6	n°8 x M6	17
RJ006	1,75	800	760	2700	n°4 x M8	n°8 x M8	41
RJ007	2,13	880	870	2500	n°4 x M8	n°8 x M8	41
RJ008	2,96	990	980	2200	n°4 x M8	n°8 x M8	41
RJ009	4,31	1420	1360	1900	n°4 x M10	n°8 x M10	83